

HOBART701 S Ridge Avenue, Troy, OH 45374
1-888-4HOBART • www.hobartcorp.com**6801
MEAT SAW****HOBART****STANDARD FEATURES**

- 3 H.P. motor
- Direct gear drive transmission
- Tri-rail carriage
- Open frame stainless steel construction
- Center crown pulley
- Removable double flanged pulleys
- Split rear table
- Direction grain stainless steel
- Pivoted automatic tension
- Stainless steel top cover
- Adjustable legs

MODEL

- 6801 – Vertical Meat Saw

Specifications, Details and Dimensions on Inside and Back.

**6801 MEAT SAW**

6801 MEAT SAW



701 S Ridge Avenue, Troy, OH 45374
1-888-4HOBART • www.hobartcorp.com

MACHINE WILL PASS THROUGH A 33" OPENING
WITH CARRIAGE AND CARRIAGE SUPPORTS
REMOVED.

NET WEIGHT: 430 LBS.
SHIPPING WEIGHT: APPROX. 570 LBS.

LEGEND:

E1-ELECTRICAL CONNECTION

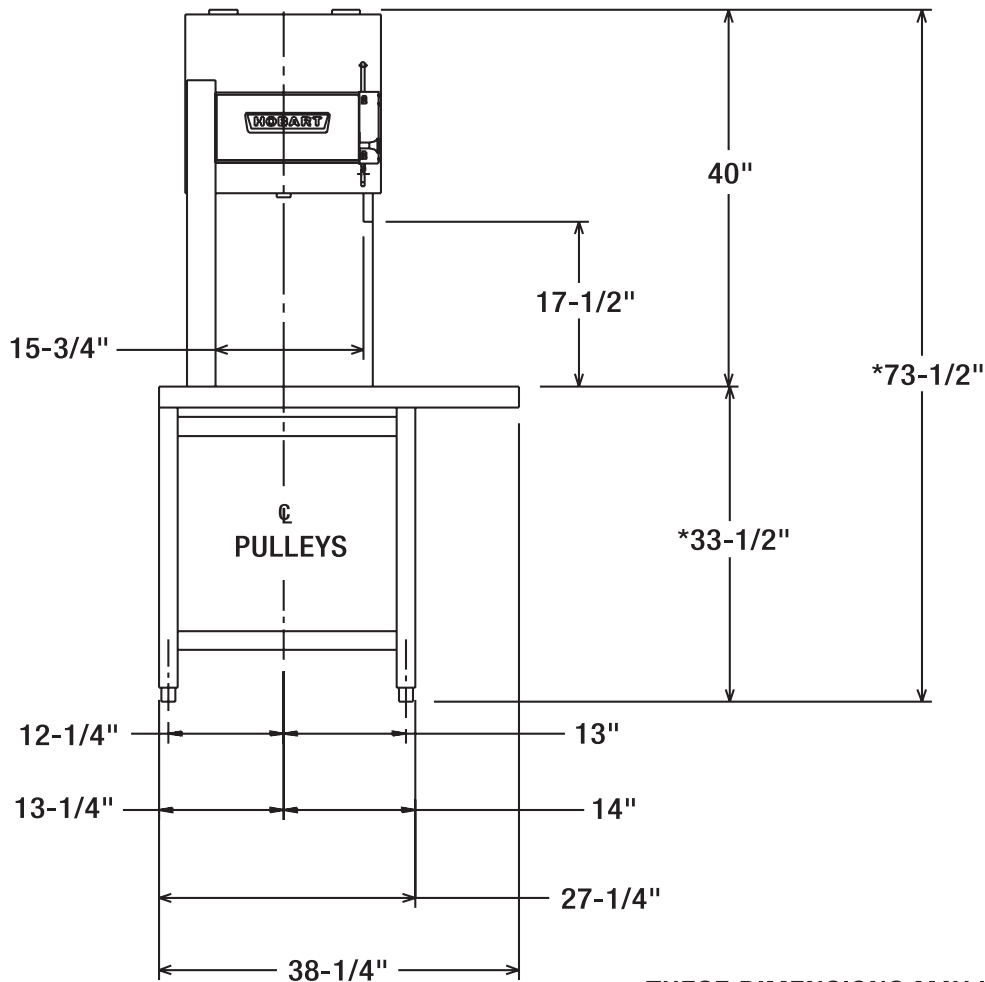
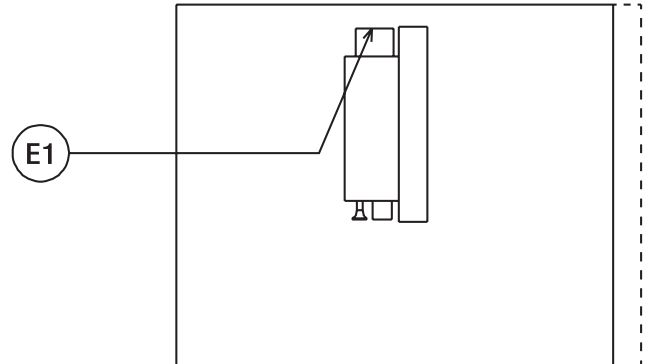

* THESE DIMENSIONS MAY INCREASE AS MUCH AS 1" DEPENDING ON LEG ADJUSTMENT.



701 S Ridge Avenue, Troy, OH 45374
1-888-4HOBART • www.hobartcorp.com

6801 MEAT SAW

WARNING

ELECTRICAL AND GROUNDING CONNECTIONS MUST COMPLY WITH APPLICABLE PORTIONS OF THE NATIONAL ELECTRICAL CODE AND/OR OTHER LOCAL ELECTRICAL CODES. CONNECTION OF CONDUIT TO BASE MUST BE MADE USING A WATERPROOF FITTING OF PROPER SIZE AND DESIGN.

7/8" DIA HOLE LOCATED AS SHOWN ON BACK OF COLUMN FOR CABLE OUTLET

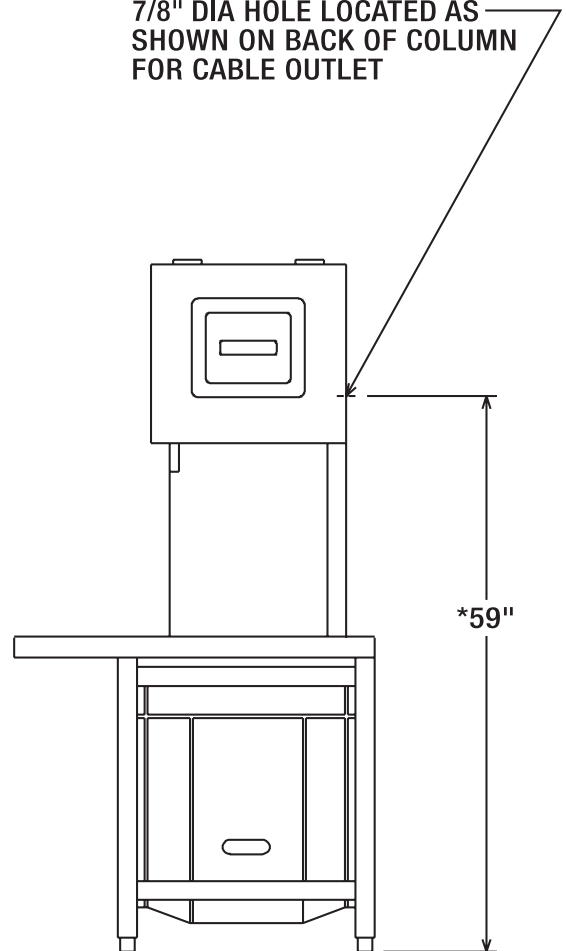
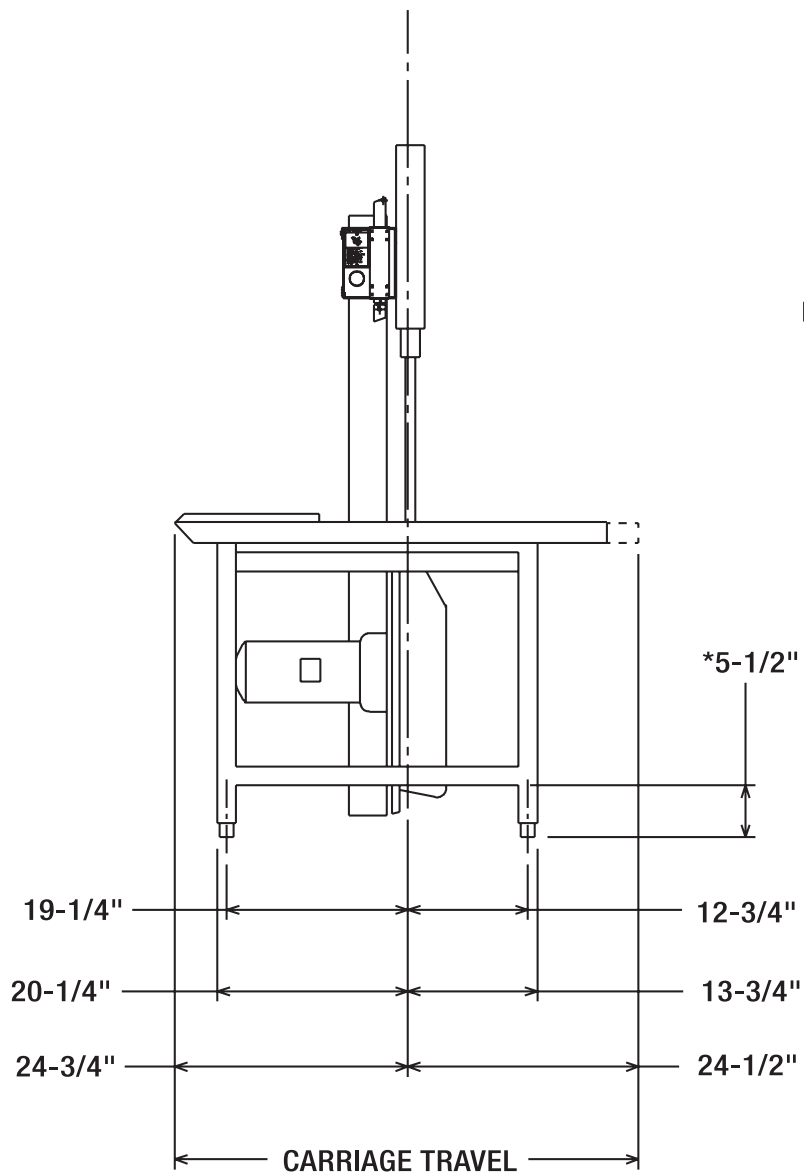

D-873795
MODEL 6801

6801 MEAT SAW



701 S Ridge Avenue, Troy, OH 45374
1-888-4HOBART • www.hobartcorp.com

SOLUTIONS / BENEFITS

3 H.P. Motor

Durability and reliability

- Totally enclosed
- Flange mounted with grease-packed ball bearings
- Water resistant

Direct Gear Drive Transmission

Performance

- No belts to replace, slip, adjust or break
- Helical gear reduction
- Blade speed; 4150 fpm

Operator Protection Features

Protection

- Upper and lower pulleys are completely enclosed
- Accessible blade is guarded above and below the cutting zone
- Pusher plate provided to eliminate handling items too close to blade

Cleanability

Labor savings, improved sanitation

- Total open construction and complete hose down capabilities
- Lower "lift-out" guide assembly has stainless steel blade guide
- Built-in tungsten carbide blade back-up block assembly is removable
- Enclosed bone dust system, with large lower scrap pan, keeps dust where it belongs
- No tools needed for part removal, including both pulleys, blade cleaners and guide assemblies
- Exclusive two-piece table and open frame design make sink washing or high pressure hose-down a cinch

Pivoted Automatic Tension

Productivity, ease of use

- Entire motor, transmission and lower pulley assembly is pivot mounted
- Blade tension control accessible just below right table
- Simple adjustment allows for broad blade length tolerance

User Friendly Controls

Ease of use

- Single pull-to-start, push-to-stop switch
- Heater provided with each control to prevent moisture condensation on electrical components

Integrated Pulley Design

Durability, reliability

- Bright tinned cast iron upper and lower blade pulleys are easily removed
- True-running of the blade is assured by precision pulley balance
- Blade retaining double flanges and center crown give long life without loss of blade integrity

Movable Carriage Tray

Convenience, labor savings

- 16" D x 24 $\frac{1}{4}$ " W
- Stainless steel, turned down edges provide reinforcements for rigidity
- Stepped front edge makes movement of carriage fast and easy
- Stainless steel ball bearings, mounted on underside of carriage
- Tri-rail carriage support assures stability and easy travel, even when operator leans heavily on carriage
- Carriage lock is provided as standard equipment

Rugged Gauge Plate

Durability, ease of operation

- Stainless steel plate on aluminum cast frame, 6 $\frac{3}{4}$ " x 16 $\frac{3}{4}$ "
- Adjustment gives quick, positive regulation of cut thickness with precision
- Easily disengaged for adjustment
- Exclusive design of gauge plate end permits quick removal of cuts for stacking

Stationary Cutting Table

Convenience, heavy duty

- Two piece, 21 $\frac{1}{2}$ " x 39 $\frac{5}{8}$ ", heavy stainless steel with turned down edges for rigidity
- Fully supported for heavy duty use
- Provides extensive stacking space and easy breakdown for cleaning

SPECIFICATIONS

Motor: 3 H.P.

Electrical: Available in 200-240/50/60/1, 200-230/60/3, 208-240/60/3 and 460/60/3. Also available in 220/50/3, 380-415/50/60/3, not submitted for UL listing.

Switch: Single pull-to-start, push-to-stop switch

Standard Leg Height: 2" (Std.) 1 $\frac{3}{4}$ " to 2 $\frac{1}{4}$ "

Optional Leg Height: 4" 3 $\frac{3}{4}$ " to 4 $\frac{1}{4}$ "

Saw Blade: $\frac{5}{8}$ " wide x 142" long

Capacity: Cutting clearance is 15 $\frac{3}{4}$ " D x 17 $\frac{1}{2}$ " H x 24" W

Weight: Net 430 lbs. Shipping: approximately 570 lbs.

As continued product improvement is a policy of Hobart, specifications are subject to change without notice.