



BIZERBA

■ ... closer to your business

Easy does it ...

... Precision Bread Slicer Agiloline B 100

Agiloline
BIZERBA



Strong in halving, quartering
or single slicing ...

Agiloline
BIZERBA

Agiloline B 100 by Bizerba meets the highest hygienic requirements. A bread slicer has never been so easy to handle, to operate and to clean.



The Precision Bread Slicer offers many opportunities to slice long and round loaves of bread up to a diameter of 30 cm in a quick, precise and particularly hygienic way. It is more flexible than a multi-blade slicer and cuts slices of the thickness exactly required by the customer.

A considerably hygienic machine of high flexibility ...

Good performance tailored to the customer's desires

A wide range of assorted breads is as important as the service you can offer with this machine. Quick operation also during a high customer frequency by qualified as well as untrained personnel. Due to a clear design the Agiloline B 100 is easy to operate and helps you to make the right decision.

This universal machine combines highest slicing quality and long-life cycle. It is silent and safe and manages any slicing challenge: soft, still warm or hard as well as thick whole-wheat bread crusts. A sophisticated slicing technology enables the new and more powerful drive to slice even breads with whole nuts. Instead of being pushed into the bread they will be sliced precisely. Speeds can be adjusted between 60 and 100 slices per minute.

Oil-free slicing has many advantages

Oil-free slicing prevents mildew growth and the transfer of germs to the cut surface of fresh bread. To the pleasure of your customers who benefit from a longer product freshness. To the pleasure of your employees who will be able to clean the machine quickly and easily. And, to your pleasure because you know that in your store all food safety and hygiene regulations can steadily be met at any time without big effort.



The protective hood with a sliding block guide can be flapped upwards and cleaned on both sides. The bread crumbs are collected in a separate compartment and can be removed quickly.



The product chute itself is completely accessible for cleaning. The cleaning position of the blade is automatically set at a keystroke combination.

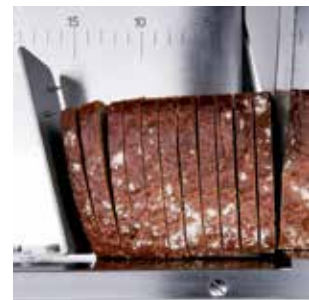

The slice thickness lies between 3 and 30 mm and can be adjusted via keys during operation. Three save keys enable quick toggling between the three slice thicknesses that can be programmed individually.

Practice gives us valuable experience. When improving the high-performance Agiloline B 100 slicer with rotating blade new user requirements have been consequently realized to new solutions.

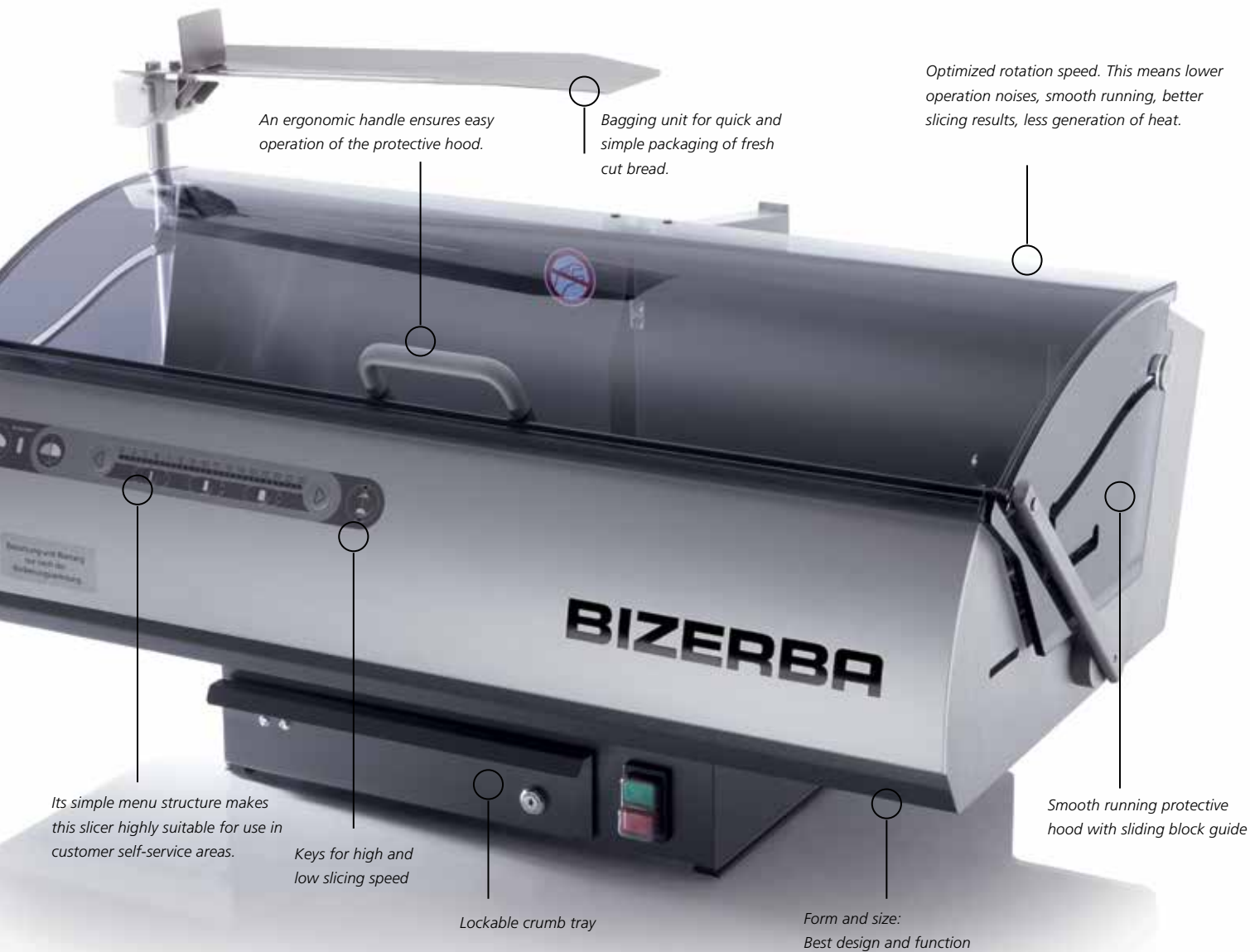

An ergonomic handle ensures easy operation of the protective hood.

Bagging unit for quick and simple packaging of fresh cut bread.

Optimized rotation speed. This means lower operation noises, smooth running, better slicing results, less generation of heat.

Its simple menu structure makes this slicer highly suitable for use in customer self-service areas.

Keys for high and low slicing speed

Lockable crumb tray

Form and size:
Best design and function

Smooth running protective hood with sliding block guide



Speed as well can be adjusted between 60 and 100 slices/min. In order to perfectly slice soft bread or any other soft product without any big effort, two speeds can be programmed and can be accessed via direct key „Slow/fast“.



Due to the simple menu structure with shortcut keys and the sophisticated protective unit the machine can also be set up in self-service areas. A lockable crumb tray makes application in these areas even better.



An optimized rotation speed lowers the operation noises and ensures a smooth machine running, better slicing results and less generation of heat.

Plug it in, start process ... that's all! ...

BIZERBA

Quality and long service life are its key features

The motor is fixed and due to a low gravity it reveals its full power in considerably smoother slicing movements. Even bread types with hard crusts are no longer a problem. Company-wide certified according to DIN EN ISO 9001 our Quality Management guarantees a high degree of product safety. The Agiloline B 100 combines all of these features. The entire product chute is made of stainless steel. The protective hood is made of food safe, stable and transparent plastic. The slicing area is therefore clearly visible. Moreover, all outer faces are powder-coated.



Best design and function

The neutral color design of the Agiloline B 100 fits naturally into any store environment and at the same time up-values the interior design of very tastefully equipped sales areas. With or without a stand - it is a pleasure working with the Agiloline B100. Thanks to superior design and high-quality material. Even hygienic cleaning in no time is extraordinary. Best design and function.

This is true partnership

High availability of valuable investments by means of preventative maintenance can be secured very easily and very effectively with Bizerba's modular choice of service contracts. The large service pack is amended by a wide range of original accessories by Bizerba and attractive financing and leasing options provided by BLG Bizerba Leasing.



BIZERBA

... closer to your business

Voltage/frequency

- 120 V / 60 Hz

Blade diameter

- 9.84" (250 mm)

Max. product aperture

- Width 11.81" (300 mm), length 14.96" (380 mm), height approx. 5.91" (150 mm), rectangular 4.92" (125 mm)

Slice thickness setting

- 0.12" - 1.18" (3 - 30 mm)

Slices per minute

- 60 - 100 slices

Outer dimensions

- Max. space required: Width 38.39" (975 mm), height 18.5" (470 mm), depth 26.89" (683 mm)
- With bagging unit: Width 38.98" (990 mm), height 21.65" (550 mm), depth 26.89" (683 mm)

Bench

- Width 25.59" (650 mm), height 27.56" (700 mm), depth 25.59" (650 mm)

Protection type

- IP 31

Net weight

- Approx. 141.09 lbs (64 kg)

Optional supplemental equipment

- Stainless steel bench
- Bagging unit

Shipping box

- Length 42.52" (1080 mm), width 32.28" (820 mm), height 25.59" (650 mm)
- Weight: 77.16 lbs (35 kg)

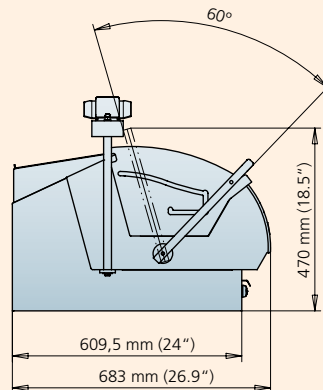
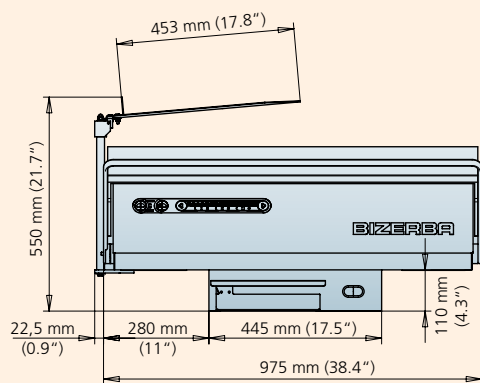

Deviations in color, printing errors due to the photographic material or printing, or changes in construction and model are reserved.

**To be raised in no time
on little space**

This compact machine can find its place everywhere. The slicer cuts a good figure with the stand that is available as an extra.



Agiloline

BIZERBA

Members of the Bizerba Group

Bizerba GmbH & Co. KG
Wilhelm-Kraut-Straße 65
72336 Balingen
Germany
Tel. +49 7433 12-0
Fax +49 7433 12-2696
marketing@bizerba.com
www.bizerba.com

Bizerba UK Limited
2-4 Erica Road
Stacey Bushes
Milton Keynes
Buckinghamshire
MK12 6HS
U.K.
Tel. +44 1908 682740
Fax +44 1908 682777
sales@bizerba.co.uk

Bizerba USA Inc.
31 Gordon Road
Piscataway
New Jersey 08854
USA
Tel. Office +1 732 565-6000
Tel. Service +1 732 565-6001
Fax +1 732 819-0429
us.info@bizerba.com
www.bizerbausa.com

Bizerba Canada Inc.
2810 Argentinia Road #9
Mississauga,
Ontario L5N 8L2
Canada
Tel. +1 905 816-0498
Fax +1 905 816-0497
ca.info@bizerba.com
www.bizerba.ca

Bizerba South East Asia Pte.
Ltd.
1 Fifth Avenue #02-05
Guthrie House
Singapore 268802
Singapore
Tel. +65 6465-1900
Fax +65 6468-0481
bizerba@bizerba-sea.com
www.bizerba-sea.com