

**HOBART**701 S Ridge Avenue, Troy, OH 45374  
1-888-4HOBART • www.hobartcorp.com**4732-4732A  
MEAT CHOPPERS****HOBART****STANDARD FEATURES**

- 3 H.P. motor
- Compact design
- Steel gears
- Oil bath transmission
- Double lip seal
- 14 gauge stainless steel pan

**OPTIONS**

- Removable pan

**ACCESSORIES**

- Floor mount legs
- #32 Stay-Sharp knife & plates
- #32 stuffing tubes

**MODEL**

- 4732 – Meat Chopper
- 4732A – Meat Chopper

Specifications, Details and Dimensions on Reverse Side.



4732A

**4732-4732A MEAT CHOPPERS**

# 4732-4732A MEAT CHOPPERS



701 S Ridge Avenue, Troy, OH 45374  
1-888-4HOBART • www.hobartcorp.com

## SPECIFICATIONS

**Motor:** 3 H.P., with ball bearings, in a sealed enclosure. Front bearing lubricated by transmission, rear bearing is grease packed, sealed for life.

**Electrical:** 200/60/1, 230/60/1, 200/60/3 and 230/60/3 – UL Listed. 380/50/3 – Not submitted for UL Listing.

**TRANSMISSION:** Double reduction, oil-lubricated hardened helical cut steel gears. Worm speed is only 151 RPM. Thrust from chopper worm is taken by a tapered roller bearing mounted in attachment hub on face of transmission housing. Double lip seal prevents loss of oil or entrance of moisture.

**GRINDER END:** This unit includes a #32 wide mouth grinding end. The cylinder is spiral fluted, equipped with a deep fluted worm, and is designed to use #32 plates. The cylinder, worm, and adjusting ring are heavily tinned cast iron.

**STAY-SHARP KNIFE & PLATES:** The Hobart Stay-Sharp knife & plates are made from an alloy steel that holds its edge longer than standard carbon steel. Stay-Sharp plates also can be resharpened many more times than regular plates. These two features allow a substantial lifetime cost benefit with the Hobart Stay-Sharp plates.

**CAPACITY:** Fresh meat capacity of 35 to 40 pounds per minute, first cutting, through a 1/8 plate – and 25 to 30 pounds of beef per minute on second cutting through a 1/8 plate.

**FEED PAN:** Feed pan features large capacity, measures 34" long, 21" wide and 4<sup>15</sup>/<sub>16</sub>" deep inside. Furnished in 14 gauge stainless steel.

A cast aluminum guard is permanently mounted to the front and sides of the pan with hardened steel drive screws. The pan is secured to the top of the housing with screws. It is separated from the motor area by a heavy sheet of fiberglass insulation to block transfer of heat from the motor compartment to the meat.

**LEGS:** Leg length on these standard table models provides 8" clearance between table and lowest point on adjusting ring. Legs in two different lengths (18" and 21") are available at extra cost to convert machine into a floor model. The floor model can be leveled, by adjusting the legs.

**STANDARD EQUIPMENT:** Consists of working power unit, magnetic-type contractor wired to water-proof junction box on rear of machine; chopping end; stainless steel feed pan with guard; tinned steel meat deflector mounted to chopping end; plastic feed stomper; cylinder wrench (for loosening cylinder nuts, adjusting ring, or removing worm).

**WEIGHT:** The chopper is shipped as two separate components – the base chopper unit and the legs. Weights for these components are:

	Net Weight	Shipping Weight
Base Unit 4732	278	318
Base Unit 4732A	280	320
5" Legs	5	6
18" Legs	20	21
21" Legs	21	22

## DETAILS AND DIMENSIONS

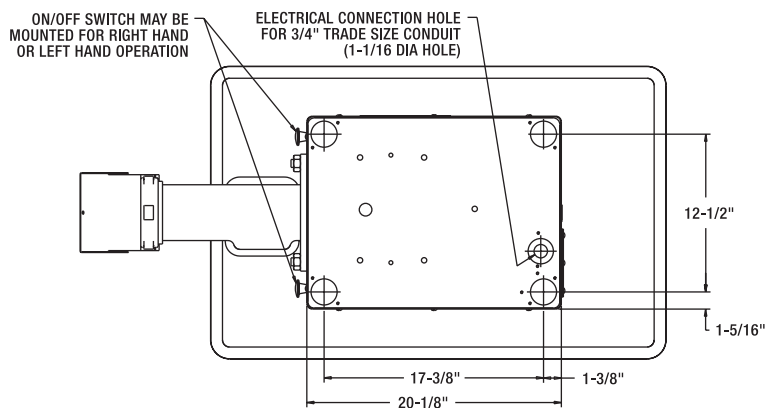
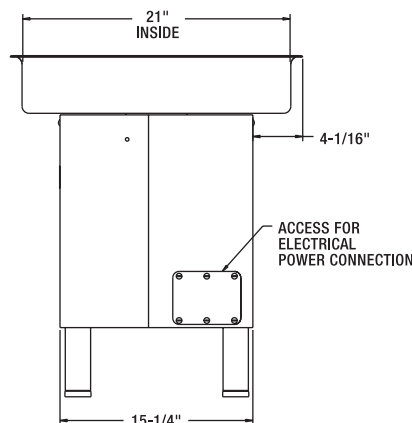
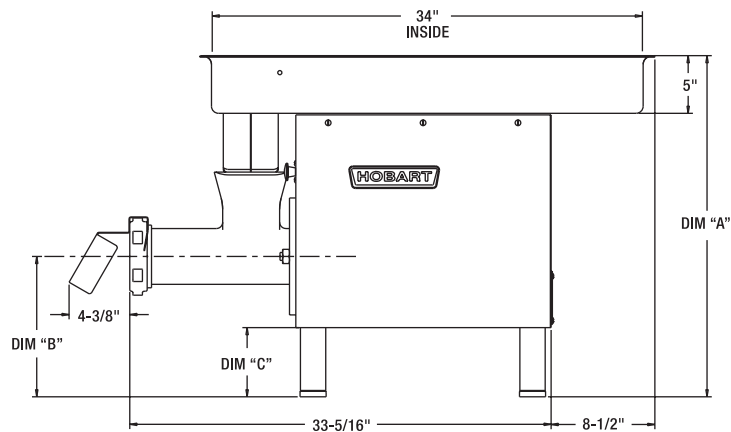

LEGS	DIM "A"	DIM "B"	DIM "C"	MODEL
5-3/8" STD	27"	10-3/4"	5-3/8"	4732
	27-3/8"			4732A
18" OPT	39-5/8"	23-3/8"	18"	4732
	40"			4732A
21" OPT	42-5/8"	26-3/8"	21"	4732
	43"			4732A

### WARNING

ELECTRICAL AND GROUNDING CONNECTIONS MUST COMPLY WITH THE APPLICABLE PORTIONS OF THE NATIONAL ELECTRICAL CODE AND/OR OTHER LOCAL ELECTRICAL CODES.

As continued product improvement is a policy of Hobart, specifications are subject to change without notice.