

HOBART701 S Ridge Avenue, Troy, OH 45374
1-888-4HOBART • www.hobartcorp.com**6430 & 6460
PEELER****HOBART****STANDARD FEATURES**

- Stainless steel housing for durability
- Silicon carbide abrasive disk easily removed for cleaning
- Stainless steel drive shaft
- Gray molded, heavy-duty hopper cover with opening to monitor product
- Peels 30 lbs. (Model 6430) or 50-60 lbs. (Model 6460) in one to three minutes
- Heavy-duty motors for high volume, long life
- ¾ H.P. (Model 6430) or 1 H.P. (Model 6460) motor
- V-belt direct speed drive
- Stainless steel construction
- NSF approved removable Lexan liner
- Synchronous 5 minute timer (single phase only)

ACCESSORIES

- Cabinet base and peel trap with stainless steel strainer

MODEL

- 6430 – Peeler
- 6460 – Peeler

Specifications, Details and Dimensions on Inside and Back.

Shown with optional
peel strainer and trap**6430 & 6460 PEELER**

6430 & 6460 PEELER



701 S Ridge Avenue, Troy, OH 45374
1-888-4HOBART • www.hobartcorp.com

DETAILS, DIMENSIONS AND CONNECTIONS OF PEELER

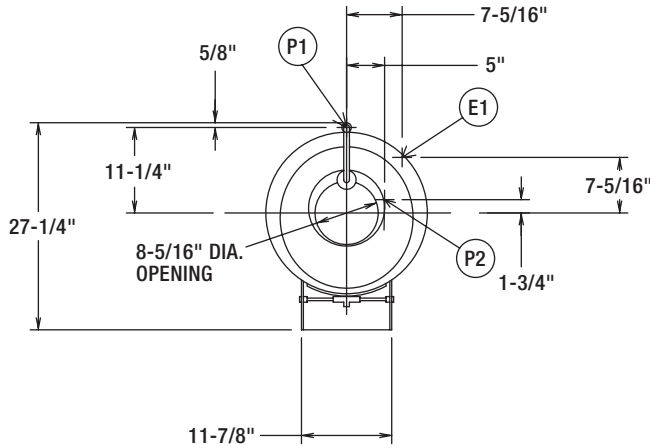

LEGEND:
 E1 - ELECTRICAL CONN.: 7/8" DIA. HOLE (FOR 1/2" CONDUIT)
 P1 - WATER CONNECTION: STANDARD 1/2" FEMALE PIPE THREAD
 P2 - DRAIN HOSE: 2-3/8" I.D.X 2-3/4" O.D.

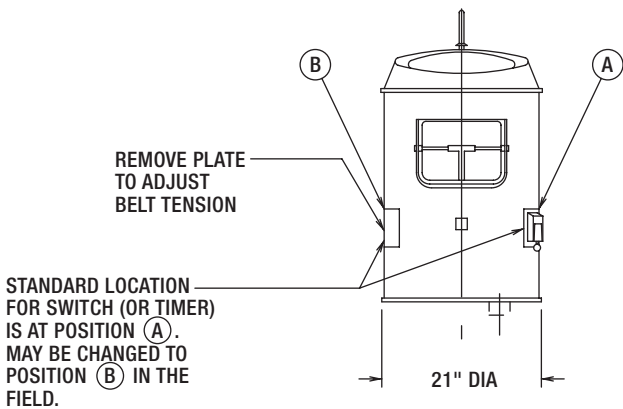

WARNING

ELECTRICAL AND GROUNDING CONNECTIONS MUST COMPLY WITH THE APPLICABLE PORTIONS OF THE NATIONAL ELECTRICAL CODE AND/OR OTHER LOCAL ELECTRICAL CODES.

PLUMBING CONNECTIONS MUST COMPLY WITH APPLICABLE SANITARY, SAFETY AND PLUMBING CODES IN FORCE.

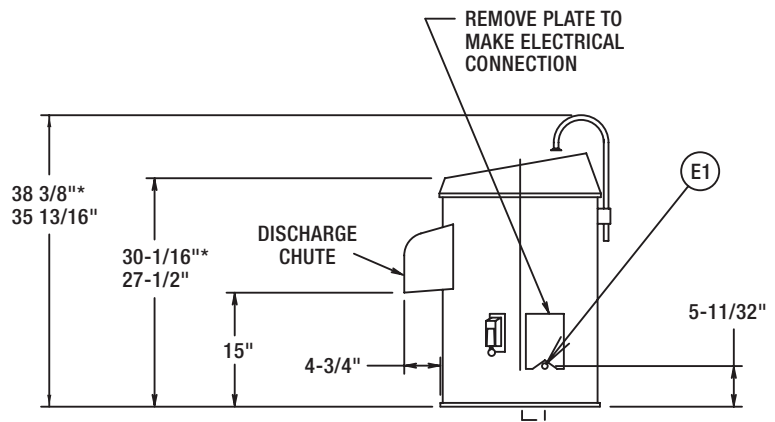
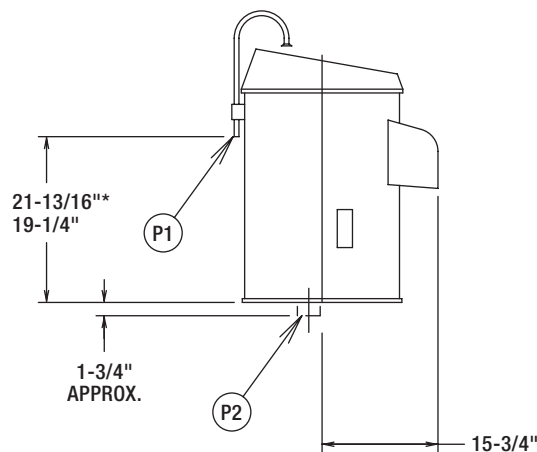

* INDICATES DIMENSIONS FOR 6460 & 6460-T

MODELS	6430	6460
Approximate Shipping Weight Peeler and Peel Trap Unit	201 lbs.	210 lbs.
Approximate Shipping Weight Peeler less Peel Trap Unit	147 lbs.	156 lbs.
Net Weight of Peeler and Peel Trap Unit	190 lbs.	198 lbs.
Net Weight of Peeler less Peel Trap Unit	142 lbs.	150 lbs.

MODEL 6430 & 6430-T
 MODEL 6460 & 6460-T
 PEELER (WITHOUT TRAP)



701 S Ridge Avenue, Troy, OH 45374
1-888-4HOBART • www.hobartcorp.com

6430 & 6460 PEELER

DETAILS, DIMENSIONS AND CONNECTIONS OF PEELER WITH PEEL TRAP UNIT

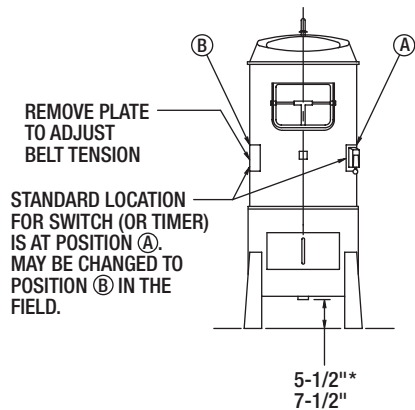
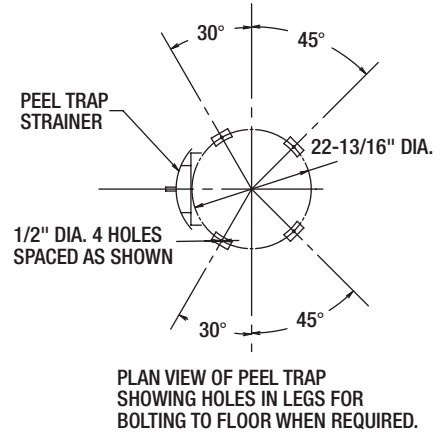
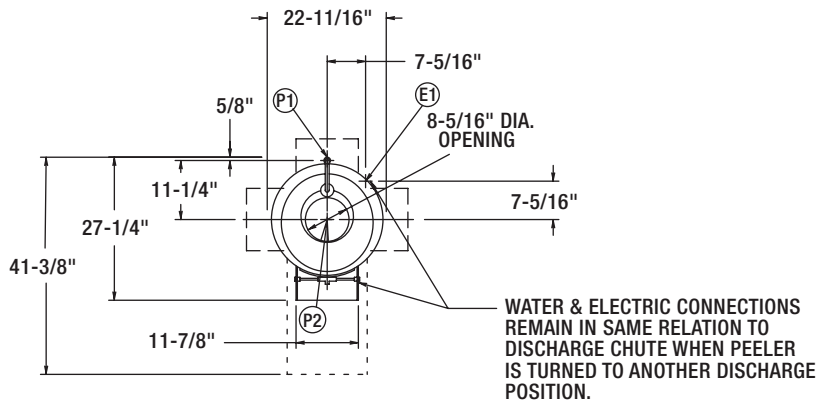

WARNING

ELECTRICAL AND GROUNDING CONNECTIONS MUST COMPLY WITH THE APPLICABLE PORTIONS OF THE NATIONAL ELECTRICAL CODE AND/OR OTHER LOCAL ELECTRICAL CODES.

PLUMBING CONNECTIONS MUST COMPLY WITH APPLICABLE SANITARY, SAFETY AND PLUMBING CODES IN FORCE.

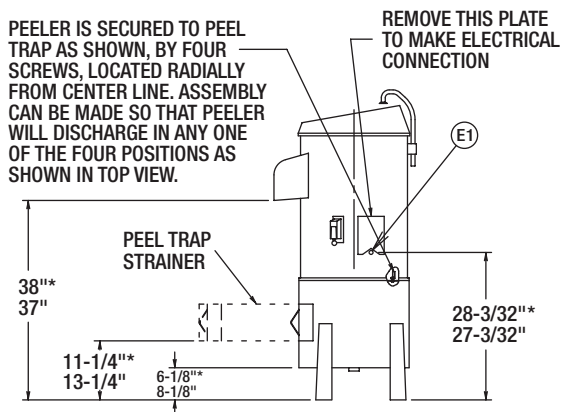
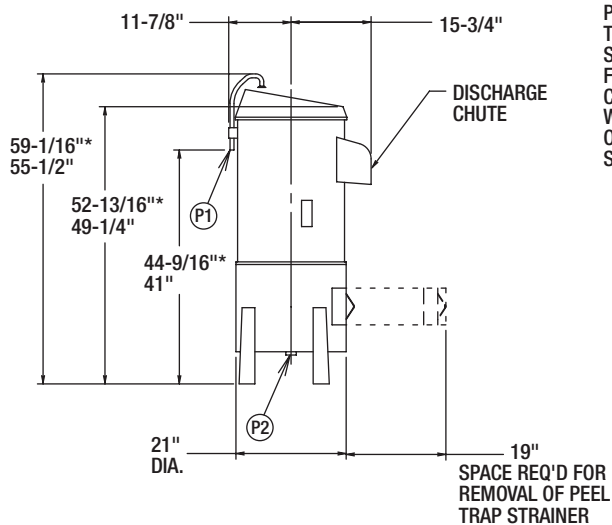

NOTES:

ALL DIMENSIONS TAKEN FROM FLOOR LINE MAY BE INCREASED AS MUCH AS 13/16" BY LEG ADJUSTMENT.

LEGEND:

- E1 - ELECTRICAL CONNECTION: 7/8" DIA. HOLE (FOR 1/2" CONDUIT)
- P1 - WATER CONNECTION: STANDARD 1/2" FEMALE PIPE THREAD
- P2 - DRAIN CONNECTION: STANDARD 2" MALE PIPE THREAD

MODEL 6460 & 6460-T
PEELER (WITH PEEL TRAP)
D-271986
REV. B

6430 & 6460 PEELER



701 S Ridge Avenue, Troy, OH 45374
1-888-4HOBART • www.hobartcorp.com

SPECIFICATIONS

MOTOR: ¾ H.P., Model 6430; 1 H.P. Model 6460. The motor features manual reset overload protection, grease-packed ball bearings, and ventilation within the peeler enclosure. Single phase is capacitor-start, induction run, and three phase is polyphase, squirrel-cage, induction-run type.

ELECTRICAL SPECIFICATIONS: 115/60/1, 200-230/60/1, 200-230/60/3 UL Listed. 220-240/50/1, 380-415/50/3 — Not submitted for UL Listing.

SWITCH: Manual tumbler type, located on right side of discharge chute as standard. Switch can be relocated to other side of chute if desired.

TIMER – Models 6430T and 6460T: Synchronous 5-minute timer, adjustable for any increments from ½ minute up to 5 minutes, with 15-second markings etched on a large timer dial. This timer is furnished only in single phase specifications as standard.

DRIVE: Multigrip, poly V-belt provides the direct speed reduction between motor and peeling disc. Belt adjustment may be accomplished from outside the machine. The stainless steel drive shaft is rigidly mounted on grease-packed ball bearings. Advanced designed triple protection sealing prevents entrance of water into shaft bearings.

PEELER UNIT: Cylindrical construction, heliarc-welded stainless steel with removable NSF approved Lexan liner. A one piece, reinforced plastic molded, lightweight, easily

removable, positive locking hopper cover is provided for easy cleaning. Quick-opening removable aluminum hopper door and positive, cam-type pressure lock. Discharge chute is ball burnished cast aluminum. To facilitate installation, the peeler unit can be positioned at 90° intervals, in relation to the peel trap unit.

ABRASIVE DISC: An extremely lightweight fiberglass reinforced plastic disc is 20½ inches in diameter. The silicon-carbide abrasive is permanently bonded to the disc, assuring unequalled long service. Disc can be easily and quickly removed for cleaning by removing the lightweight hopper cover. Two angle mounted wipers provide positive movement of waste into the outlet.

WORKING CAPACITY: Model 6430 peels 30-33 pounds in one to three minutes. Model 6460 Peeler peels 50-60 pounds in similar time.

FINISH: Peeler and peel trap unit are glass-beaded stainless steel. Plastic molded hopper cover is gray. Door and handle, discharge chute, and legs are cast aluminum and ball burnished for durability. Bottom of peeler unit is cushioned in resilient rubber trim molding.

WATER INLET: The inlet is the air-gap type, mounted at the rear of the peeler unit at sufficient height to meet plumbing codes. The water from the inlet impinges on the curved surface of the hopper cover to form a fan pattern of water into the unit. This design promotes interior self-cleaning and forms a water curtain which prevents undesirable splash.

SOLUTIONS / BENEFITS

Increased Productivity – eliminates mundane task of peeling; employees can be assigned to other responsibilities

Improves Yield – minimizes peel waste, providing increased portions per load

Reduces Labor – peels 15-20 pounds of potatoes and most root type vegetables in just 3 minutes

Easy to Clean – designed for fast and thorough cleaning procedures

Rear Mounted Water Inlet with 5' Fill Hose

Cleanability, meets plumbing codes

- Water from inlet strikes curved surface of hopper cover, promoting interior self-cleaning and preventing undesirable splash
- Sufficient height to meet plumbing codes

Satin Stainless Steel Finish Housing

Durability, easy clean-up

- Cylindrical construction heliarc-welded stainless steel

Five Minute Timer

Convenience, consistency, easy to use

- Simplistic five minute timer adjusts for any increments from ½ to 5 minutes; with 15 second markings on large timer dial for consistent results
- Only available in single phase

Silicon Carbide Abrasive Disk

Longevity of service, convenience, cleanability

- 14¾" diameter lightweight fiberglass reinforced plastic disk with silicon abrasive permanently bonded for high volume usage
- Easily and quickly removed for cleaning

Stainless Steel Drive Shaft

Durability and reliability

- Advanced design for long life and performance

Removable NSF Lexan Liner

Durability, easy to clean

- Easily and quickly removed for cleaning, offering a higher level of sanitation
- Peels faster and with higher quality

As continued product improvement is a policy of Hobart, specifications are subject to change without notice.