

**HOBART**701 S Ridge Avenue, Troy, OH 45374  
1-888-4HOBART • www.hobartcorp.com**6614  
MEAT SAW****HOBART****STANDARD FEATURES**

- Reduced footprint
- 3 H.P. motor
- Direct gear drive transmission
- Tri-rail carriage
- Open frame stainless steel construction
- Center crown pulley
- Removable double flanged pulleys
- Split rear table
- Direction grain stainless steel
- Pivoted automatic tension
- Adjustable legs

**MODEL**

- 6614 – Vertical Meat Saw

Specifications, Details and Dimensions on Inside and Back.

**6614 SERIES MEAT SAW**

# 6614 MEAT SAW



701 S Ridge Avenue, Troy, OH 45374  
1-888-4HOBART • www.hobartcorp.com

MACHINE WILL PASS THROUGH A 33" OPENING.

NET WEIGHT: 410 LBS.

SHIPPING WEIGHT: APPROX. 550 LBS.

## LEGEND:

E1-ELECTRICAL CONNECTION

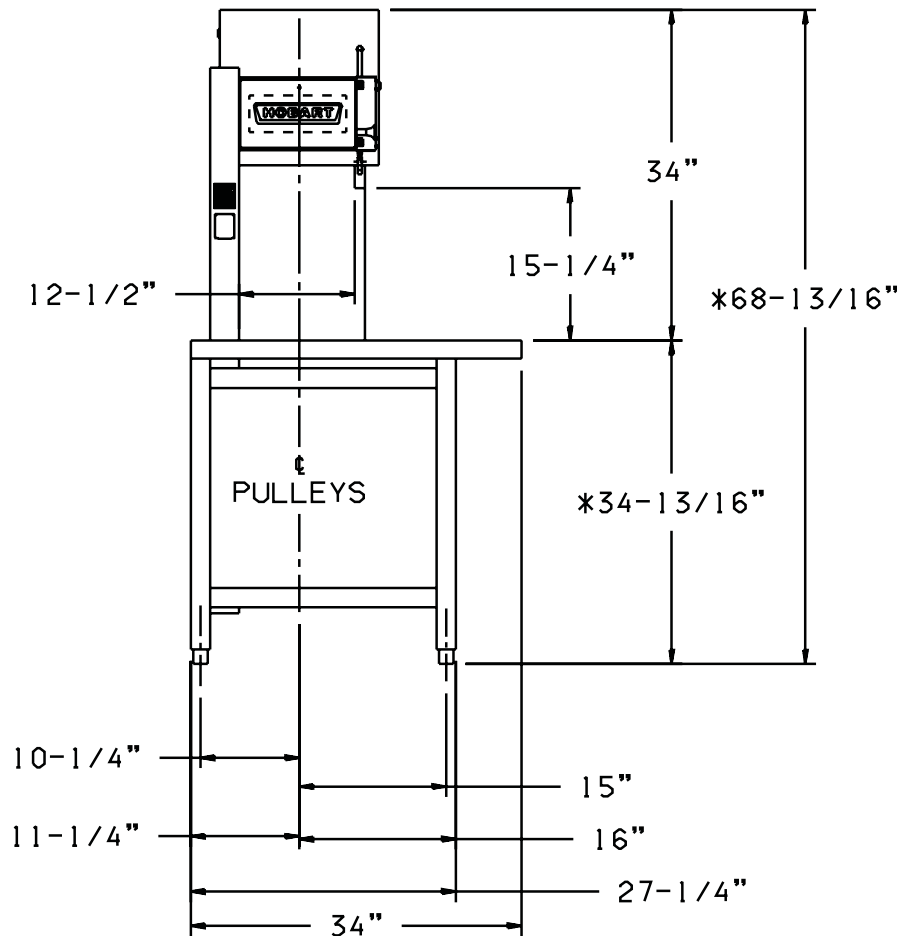
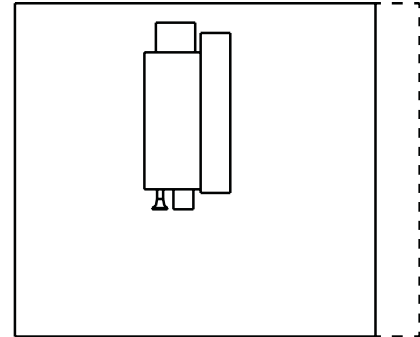

\* THESE DIMENSIONS MAY INCREASE AS MUCH AS 1" DEPENDING ON LEG ADJUSTMENT.



701 S Ridge Avenue, Troy, OH 45374  
1-888-4HOBART • www.hobartcorp.com

# 6614 MEAT SAW

## WARNING

ELECTRICAL AND GROUNDING CONNECTIONS MUST COMPLY WITH APPLICABLE PORTIONS OF THE NATIONAL ELECTRICAL CODE AND/OR OTHER LOCAL ELECTRICAL CODES. CONNECTION OF CONDUIT TO BASE MUST BE MADE USING A WATERPROOF FITTING OF PROPER SIZE AND DESIGN

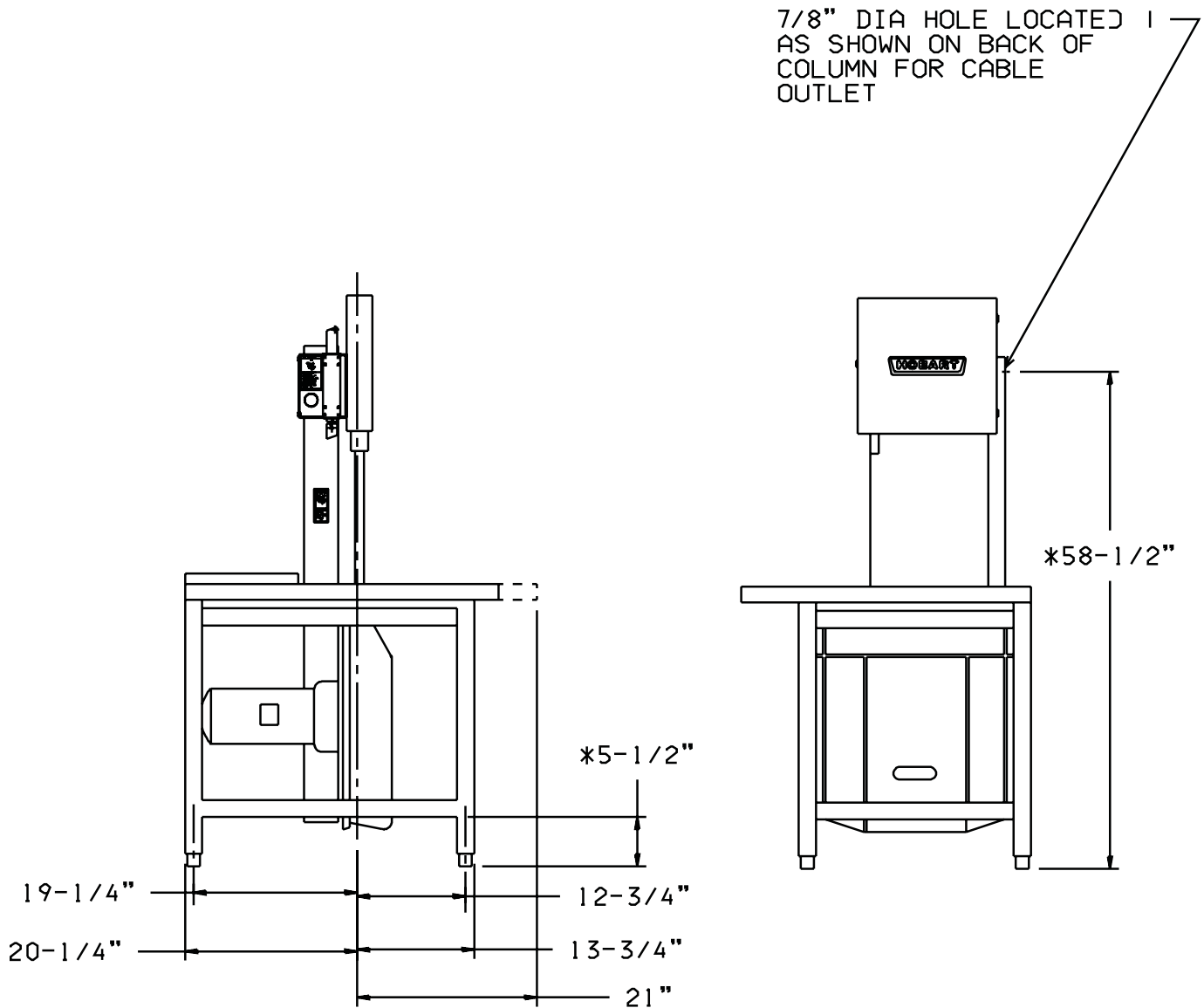

# 6614 MEAT SAW



701 S Ridge Avenue, Troy, OH 45374  
1-888-4HOBART • www.hobartcorp.com

## SOLUTIONS / BENEFITS

### 3 H.P. Motor

Durability and reliability

- Totally enclosed
- Flange mounted with grease-packed ball bearings
- Water resistant

### Direct Gear Drive Transmission

Performance

- No belts to replace, slip, adjust or break
- Helical gear reduction
- Blade speed; 3500 fpm

### Operator Protection Features

Protection

- Upper and lower pulleys are completely enclosed
- Accessible blade is guarded above and below the cutting zone
- Pusher plate provided to eliminate handling items too close to blade

### Cleanability

Labor savings, improved sanitation

- Total open construction and complete hose down capabilities
- Lower "lift-out" guide assembly has stainless steel blade guide
- Built-in tungsten carbide blade back-up block assembly is removable
- Enclosed bone dust system, with large lower scrap pan, keeps dust where it belongs
- No tools needed for removal of parts, including both pulleys, blade cleaners and guide assemblies
- Exclusive two-piece table and open frame design make sink washing or high pressure hose-down a cinch

### Pivoted Automatic Tension

Productivity, ease of use

- Entire motor, transmission and lower pulley assembly is pivot mounted
- Blade tension control accessible just below right table
- Simple adjustment allows for broad blade length tolerance

### User Friendly Controls

Ease of use

- Single pull-to-start, push-to-stop switch
- Heater provided with each control to prevent moisture condensation on electrical components

### Integrated Pulley Design

Durability, reliability

- Bright tinned cast iron upper and lower blade pulleys are easily removed
- True-running of the blade is assured by precision pulley balance
- Blade retaining double flanges and center crown give long life without loss of blade integrity

### Movable Carriage Tray

Convenience, labor savings

- 14½" D x 19¾" W
- Stainless steel, turned down edges provide reinforcements for rigidity
- Stepped front edge makes movement of carriage fast and easy
- Six stainless steel ball bearings, mounted on underside of carriage
- Tri-rail carriage support assures stability and easy travel, even when operator leans heavily on carriage
- Carriage lock is provided as standard equipment

### Rugged Gauge Plate

Durability, ease of operation

- Stainless steel plate on aluminum cast frame, 6¾" x 16¾"
- Adjustment gives quick, positive regulation of cut thickness with precision
- Easily disengaged for adjustment
- Exclusive design of gauge plate end permits quick removal of cuts for stacking

### Stationary Cutting Table

Convenience, heavy duty

- Two piece, 18¼" x 34½", heavy stainless steel with turned down edges for rigidity
- Fully supported for heavy duty use
- Provides large stacking space and easy breakdown for cleaning

## SPECIFICATIONS

**Motor:** 3 H.P.

**Electrical:** Available in 200-240/50/60/1, 200-230/60/3, 208-240/60/3, 460/60/3. Also available in 220/50/3, 380-415/50/60/3, not submitted for UL listing.

**Switch:** Single pull-to-start, push-to-stop switch

**Standard Leg Height:** 2" (Std.) 1¾" to 2¼"

**Optional Leg Height:** 4" 3¾" to 4¼"

**Saw Blade:** 5/8" wide x 126" long

**Capacity:** Cutting clearance is 12½" D x 15¼" H x 20" W

**Weight:** Net 410 lbs. Shipping: approximately 550 lbs.

Machine will pass through a standard 33" door.

As continued product improvement is a policy of Hobart, specifications are subject to change without notice.