

**BIZERBA**

■ ... closer to your business

■ Slice for slice precision ...

... Bizerba slicing machines A 400 and A 400 FB



**BIZERBA**

Cost-effectiveness and precision are in demand wherever different types of sliceable food are produced in large volumes. The fully automatic slicing machines A 400 and A 400 FB from Bizerba offer both – so you are always a cut above.

■ Fully automatic high performance ...

**BIZERBA**

... with cutting edge technology ...

#### **Two experts at work**

Butchers, food retailers and caterers need slicing machines which are ready for use at any time and adapt to everyday demands. The fully automatic models A 400 and A 400 FB not only show what they are capable of in these areas but also in selected industrial sectors. Efficiently, durably and with perfect results.



#### **One line, two versions**

Both models are absolutely identical in terms of their smooth handling, first-class quality material, performance, easy cleaning and maintenance.

What distinguishes them is the FB suffix, which stands for "Förderband" in German, or conveyor belt in English. This additional function means that the only slight differences between the two models are in terms of automatic transport and external dimensions, which are shown in the technical data at the end of this brochure.

The demands made of a fully automatic slicing machine are as varied as the produce they cut. Bizerba knows what a wide range of jobs can come up and provides you with mature technologies which leave no questions unanswered.

## An abundance of functions ...

### Professional machines with 200 programmes

When it comes to producing cold cuts Bizerba's slicing machines are real multi-talents, with a practical approach to automatic transport, slicing, portioning and presentation. It starts with their memory capacity for 200 presentation programmes which enable them to reveal their full potential in continuous operations.

Securing the produce is only thing that needs to be done manually; after that everything runs according to the programme chosen by the operator.

Stacking, fanning, shingling, the number of slices or portions, produce size and slice thickness – all your specifications are carried out automatically.

- Carriage with integrated powered produce feed
- The product clamp retracts automatically once all produce has been cut
- Carriage lengths of 200, 400 and 600 mm can be selected to avoid wastage at start and finish
- Programmable, continuously variable adjustment of carriage strokes from 30-55 strokes/min.
- 3-digit PLU key to save and retrieve defined slicing parameters such as slice thickness, presentation pattern, slicing speed etc.
- Best presentation by lowering the receiving tray, enabling particularly high stacks of max. 90 mm
- Extremely precise and even slice width



**BIZERBA**

■ ... closer to your business

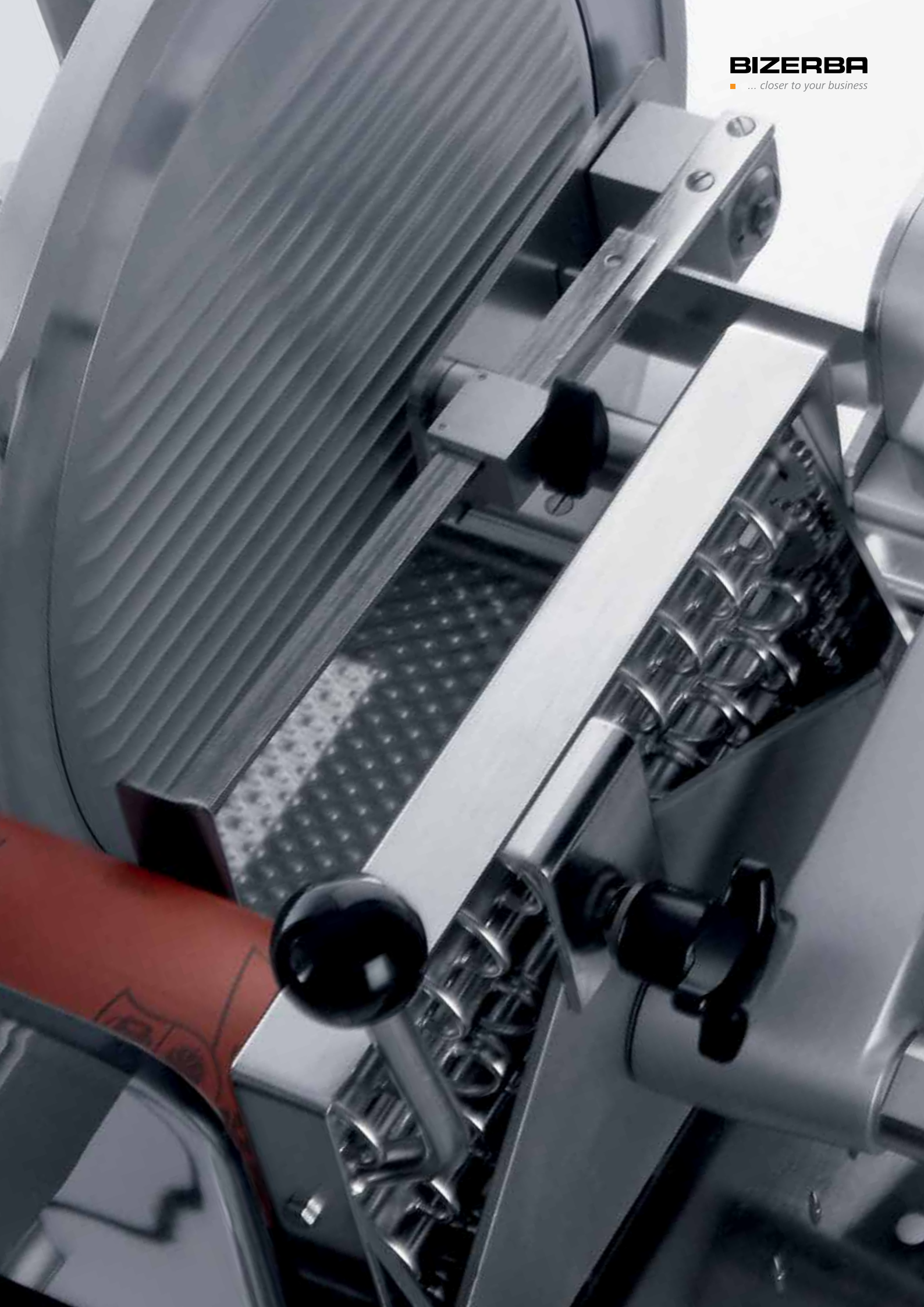

**Your staff should find it easy to work with, without extensive training. And that is a particular feature of the A 400 and A 400 FB slicing machines. With clear operating elements and simple handling they set standards which revolutionise cold cutting technology.**

## For enormous flexibility ...

### **Strong performance, sensitive solution**

In terms of produce to be sliced the A 400 and A 400 FB are variable fully-automatic machines of a very high quality. Sausages, ham, bacon, smoked or roast meats, roast beef, raw meat, cutlets or cheese – they are all cut into accurate slices and laid out in a decorative and appetising way. The slicing speed is programmable and continuously variable, so it can be adjusted precisely and sensitively to delicate produce.

### **Convincing technology**

The fully automatic A 400 has three carriage models and the A 400 FB two, so that even long produce can be fed through without the need for reclamping, which saves time. A powerful motor and the proven hollow-ground blade made of special hard chromium plated steel ensure constantly high slicing quality.

And that's not all.

The slice tray can be programmed for different packaging lengths, so that portions can be packaged manually after slicing.

### **Clarity at first sight**

The heart of the fully-automatic A 400 and A 400 FB series is an innovative operating terminal with easy-to-read, graphic-enabled LCD display and self-explanatory symbols. It enables radically simplified and safe handling without any special knowledge. A total of 6 individual slicing parameters (e.g. for fan shape or stacks) and 12 dynamic direct keys provide a wealth of different programming options. Attractively presented food can be produced at the touch of a button.

### **Always spick and span**

Hygiene has absolutely top priority in the food industry. That's why Bizerba has provided the operating unit with a splashproof keyboard and placed it outside the soiling area. It is also movable and can be set to an optimal operating position at any time.



First-class operating comfort ...



# We've thought of everything ...

## One programme, one product

Rapid and simple identification of your products during the cutting process is absolutely vital. Using a 3-digit PLU key the Bizerba slicing machines enable flexible programming and adapts to your product range at the same time. By entering numerical PLUs multiple slicing parameters can be saved and retrieved and saved products can be sorted in no time.

## Operations made easy

The new operating panel from Bizerba makes the dialogue between human and machine as easy as can be. It uses just five, clearly structured menu items to cover a multitude of programme options – receiving tray, working area, PLU area, measurement area, information area.

## The benefits at a glance

- All slicing parameters are set automatically when the corresponding programme is retrieved to avoid wastage
- The product clamp retracts automatically once all produce has been cut
- The sharpening and cleaning programmes can be activated safely and simply via direct key





**Bizerba  
slicing machine  
A 400**



Even for intelligent technology the first impression is what counts – and that is mostly a matter of appearance. Bizerba hasn't just equipped its fully automatic machines with an attractive exterior, but also with a safe, hygienic interior.

## Brilliant design à la Bizerba ...

### Stylish design, durable technology

The fully automatic slicing machines A 400 and A 400 FB put on a stylish performance in every workplace. Their discrete and robust anodised aluminium casings are as functional as they are brilliant. Combined with superlative materials, high-quality finishing and talented technology they attain the quality our customers deserve and expect: at first sight modern, at the second precise, and after that timeless and lastingly reliable.

### Always on the safe side

The fully-automatic A 400 and A 400 FB slicing machines have been developed in accordance with Machines Directive No. 89/392/EEC for safety and hygiene and approved by an accredited test laboratory under registered design test No. 94106 and GS safety test No. 94107. The EC Declaration of Conformity contained in the operating manual certifies compliance with the regulations. Some models are also UL and cUL approved.

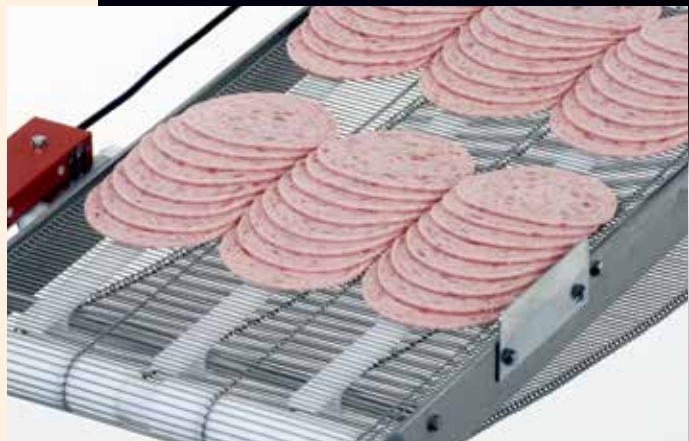

- A 404 US
- A 404 FB US
- A 406 US
- A 406 FB US



- A 404
- A 404 FB
- A 406
- A 406 FB

**Bizerba  
slicing machine  
A 400 FB**

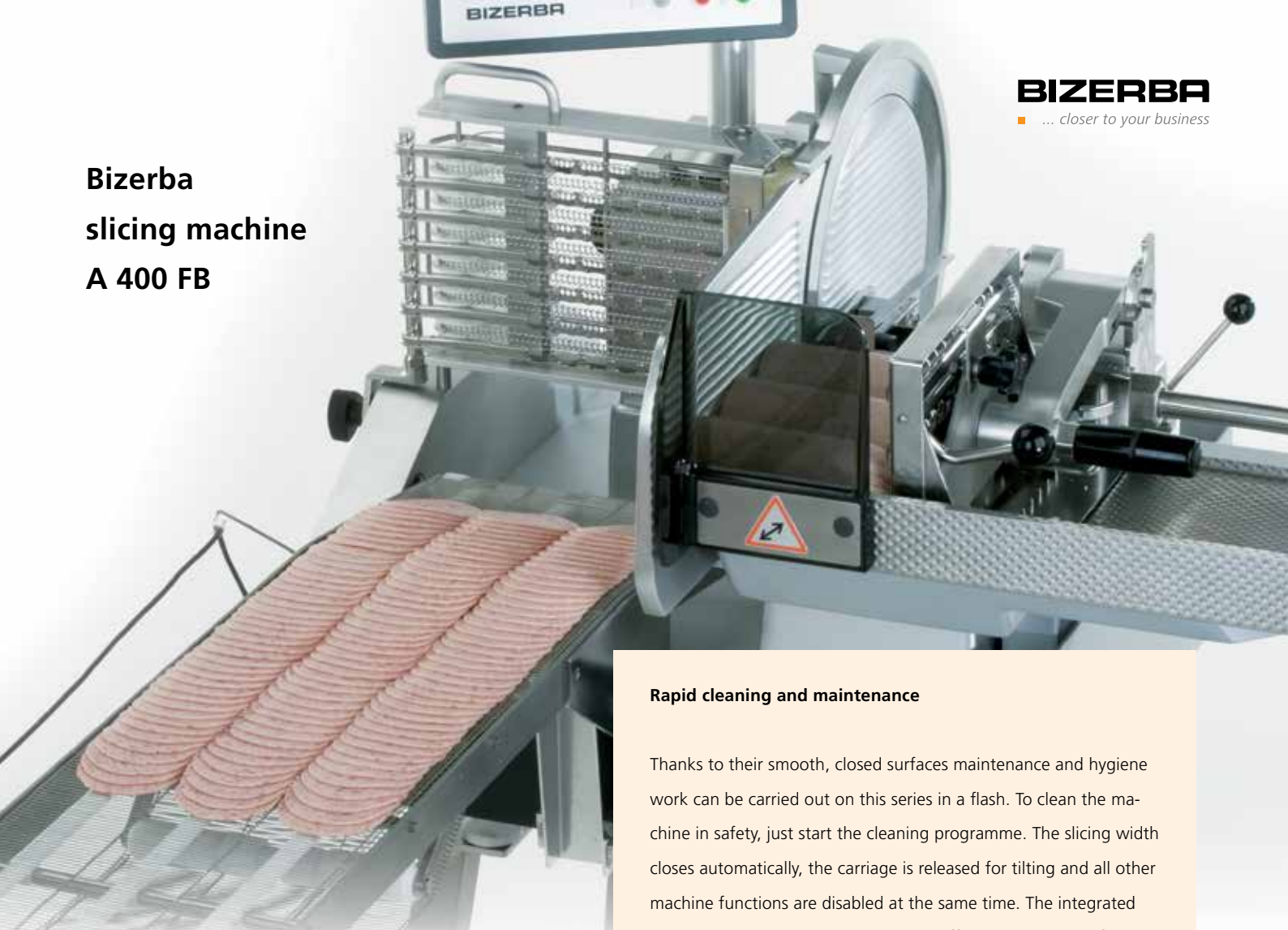

**Rapid cleaning and maintenance**

Thanks to their smooth, closed surfaces maintenance and hygiene work can be carried out on this series in a flash. To clean the machine in safety, just start the cleaning programme. The slicing width closes automatically, the carriage is released for tilting and all other machine functions are disabled at the same time. The integrated

blade sharpening programme offers additional comfort and can be activated at the touch of a button. This automatically opens the slicing width to allow the sharpening device to be attached. Once the sharpening device has been fitted and the start key is pressed, the blade begins to turn. Individual elements such as the feeder device, receiving arm, conveyor belt, produce clamp and blade cover can all be removed in just a few steps. Large radiuses and plenty of space between the components also make the fully automatic machines easy to clean.



Current type	Voltage <sup>1)</sup>	Frequency	Nominal input	Power input	A 400
	V	Hz	A	kW	

Single phase AC	230	50	3,1	0,7	
Three-phase AC	230/400	50	2,5/1,4	0,6	

<sup>1)</sup>Voltage varies according to country

#### Blade diameter

- 330 mm

#### Blade speed

- 266 rpm

#### Max product size

- Round: min. 50 mm, max. 180 mm
- Square: min. 50 x 50 mm, max. (W x H) 240 x 175 mm

#### Slice thickness

- 0,5 - 12 mm

#### Programme memory

- 200

#### Number of strokes

- Variable 30 - 55 strokes per minute

#### Stack size

- Max 60 mm (FB), 90 mm (tray)

#### Receiving tray

- 254 x 346 mm

#### Paper/foil size

- 1/8 sheet, min 360 x 240 mm, max 375 x 250 mm

#### Footprint (on work surface)

- (W x D) 410 x 490 mm, reduced: (W x D) 410 x 400 mm

#### Working area

- A 402**, (W x D x H) 990 x 860 x 810 mm  
Carriage for 200 mm produce length
- A 404**, (W x D x H) 1190 x 860 x 810 mm  
Carriage for 400 mm produce length
- A 406**, (W x D x H) 1300 x 860 x 680 mm  
Carriage for 600 mm produce length
- A 404 FB**, (W x D x H) 1190 x 1730 x 1510 mm  
Carriage for 400 mm produce length
- A 406 FB**, (W x D x H) 1300 x 1730 x 1380 mm  
Carriage for 600 mm produce length

#### External dimensions

- A 402**, (W x D x H) 850 x 800 x 680 mm
- A 404**, (W x D x H) 1050 x 800 x 680 mm
- A 406**, (W x D x H) 1250 x 800 x 680 mm
- A 404 FB**, (W x D x H) 1050 x 1730 x 1380 mm
- A 406 FB**, (W x D x H) 1250 x 1730 x 1380 mm

#### Gross weight

- A 402, A 404, A 406**, 155 kg  
Stand 23 kg
- A 404 FB, A 406 FB**, 188 kg  
Stand 23 kg

#### Packing crate

- A 402, A 404, A 406**, (W x D x H) 108 cm x 90 cm x 102 cm
- A 404 FB, A 406 FB**, (W x D x H) 132 x 90 x 105 cm

#### A 400

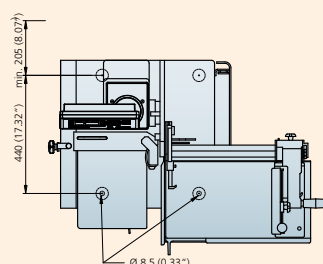
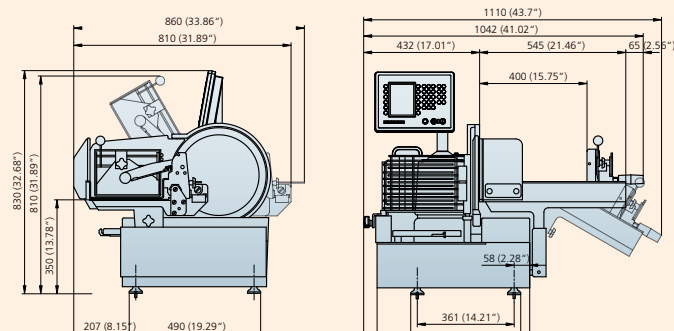

#### A 400 FB

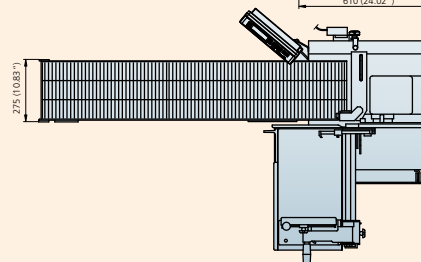
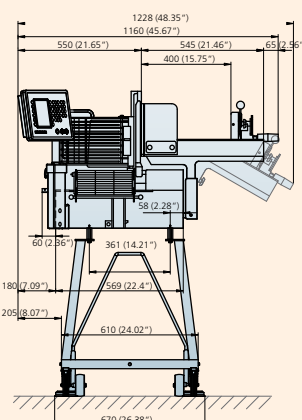
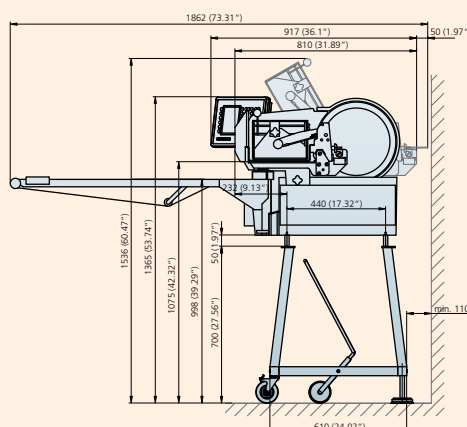

#### Members of the Bizerba Group

Bizerba GmbH & Co. KG  
Wilhelm-Kraut-Straße 65  
72336 Balingen  
Germany  
Tel. +49 7433 12-0  
Fax +49 7433 12-2696  
marketing@bizerba.com  
www.bizerba.com

Bizerba UK Limited  
2-4 Erica Road  
Stacey Bushes  
Milton Keynes  
Buckinghamshire  
MK12 6HS  
U.K.  
Tel. +44 1908 682740  
Fax +44 1908 682777  
sales@bizerba.co.uk

Bizerba USA Inc.  
1804 Fashion Court  
Joppa, MD 21085  
USA  
Tel. Office +1 732 565-6000  
Tel. Service +1 732 565-6001  
Fax +1 732 819-0429  
us.info@bizerba.com  
www.bizerbausa.com

Bizerba Canada Inc.  
2810 Argentina Road #9  
Mississauga,  
Ontario L5N 8L2  
Canada  
Tel. +1 905 816-0498  
Fax +1 905 816-0497  
ca.info@bizerba.com  
www.bizerba.ca

Bizerba (Shanghai) Weigh Tech  
& Systems Co.Ltd.  
D-3, Qianpu Road, Shuhui Real Est.Park  
East New Area of Songjiang, Ind.Zone  
201611 Shanghai  
China  
Tel. +86 (21) 67 60 09 99  
Fax +86 (21) 67 60 09 98  
marketing.china@bizerba.cn  
www.bizerba.cn