

HOBART701 S Ridge Avenue, Troy, OH 45374
1-888-4HOBART • www.hobartcorp.com**FP250
FOOD PROCESSOR****HOBART****STANDARD FEATURES**

- Red OFF, Green ON Buttons
- Compact Design
- Angled Front
- Planetary Drive
- Large Full Size Feed Hopper
- All Aluminum Hopper and Housing
- Double Interlock Switch
- Plate Speed 420 RPM
- Decoring Screw
- Hobart Ergo Loop Pusher Plate
- Powerlink Lever

MODEL

- FP250 Continuous Feed Full Hopper Food Processor

Specifications, Details and Dimensions on Inside and Back.

**OPTIONS**

- Maximum Security Correctional Package

ACCESSORIES

- 3-Pack Plates: $\frac{1}{16}$, $\frac{5}{32}$ slicer plates, $\frac{3}{16}$ shredder plate, 1 wall rack
- 6-Pack Plates: $\frac{1}{16}$, $\frac{5}{32}$, $\frac{3}{8}$, $\frac{7}{32}$ slicer plates, $\frac{3}{16}$ shredder plate and $\frac{3}{8}$ dicer plate, 2 wall racks
- 3-Peg Wall Rack: designed to hold three plates for additional plate storage
- Slicer Plates: $\frac{1}{32}$, $\frac{1}{16}$, $\frac{5}{64}$, $\frac{1}{8}$, $\frac{5}{32}$, $\frac{7}{32}$, $\frac{5}{16}$, $\frac{3}{8}$, $\frac{5}{8}$; $\frac{5}{32}$ crimping plate
- Soft Slicing Plates: $\frac{5}{16}$, $\frac{3}{8}$, $\frac{1}{2}$, $\frac{5}{8}$
- Julienne Plates: $\frac{5}{64}$, $\frac{5}{32}$, $\frac{5}{16}$
- Dicer Grids: $\frac{7}{32}$, $\frac{5}{16}$, $\frac{3}{8}$, $\frac{1}{2}$, $\frac{5}{8}$, $\frac{3}{4}$
- Shredder Plates: $\frac{1}{16}$, $\frac{5}{64}$, $\frac{1}{8}$, $\frac{3}{16}$, $\frac{7}{32}$, $\frac{5}{16}$, $\frac{3}{8}$
- Grater Plate: Fine, Hard Cheese
- Machine Table: Adjustable height table to hold Food Processor
- Adjustable height stainless steel lug cart
- Stainless steel receiving pan
- Plastic receiving pan

**FP250 FOOD PROCESSOR**

FP250 FOOD PROCESSOR



701 S Ridge Avenue, Troy, OH 45374
1-888-4HOBART • www.hobartcorp.com

SOLUTIONS/BENEFITS

Red OFF, Green ON Button

Ease of use

- Operator can readily recognize

Compact Design

Ease of use, small footprint, reduced labor, increased sanitation and productivity

- Occupies minimal counter space
- Unit and receiving pan fit on 23" deep counter
- Plates remove in seconds
- Feed hopper removes without tools for ease of cleaning
- Produces consistent quality product results in seconds
- Production capability for 17 lbs. per minute

Angled Front

Operator convenience, ease of use

- 50° angle for ease of product loading
- Helps to reduce operator fatigue

Planetary Drive

Performance, reliability

- Helps to prevent stalling under heavy loads
- No rest times required between loads

Large Full Size Feed Hopper

Flexibility, convenience, reduced labor

- Supports processing capabilities for large variety of products
- Design permits continuous cutting of long products
- Eliminates precutting

All Aluminum Hopper and Housing

Durability, sanitation

- Anodized finish resists harsh cleaners
- Easy clean up

Double Interlock Switch

Protection

- Prevents machine from running when pusher plate swings away or is open

Plate Speed of 420 RPM

Product quality and consistency

- Precise cutting and dicing action without bruising or mashing of products

Decorating Screw

Quality, consistency

- Deflects products away from the plate hub for complete processing

Ergo Loop

Flexibility, operator convenience

- Operator can use either hand to push feeder and load product

Powerlink

Leverage

- Less downward pressure needed to process dense products



701 S Ridge Avenue, Troy, OH 45374
1-888-4HOBART • www.hobartcorp.com

FP250 FOOD PROCESSOR

SPECIFICATIONS

DESIGN: Compact, conveniently designed at 50° angle for operator convenience. Small base occupies minimal counter space. Carrying handle on back of housing designed for ease of moving unit. Housing constructed of anodized aluminum with rubber feet on base to prevent movement or skidding. Feed hopper cover is burnished aluminum. Cylindrical feed hopper, pusher and deflector plate of acetal thermoplastic.

ELECTRICAL: 120/60/1, 3 Conductor power cord (18 AWG) is 6 feet in length.

MOTOR: 8 amps. Planetary gear driven operating at 420 rpm output. ¾ H.P. with overload protection.

SWITCHES: Easy to operate (red) OFF and (green) ON switch. Pusher plate and feed hopper interlocks.

STANDARD EQUIPMENT: Basic unit with deflector plate, decoring screw and cleaning brush.

WARRANTY: Unit has full one-year warranty on parts, labor and mileage against manufacturer's defects. Service contracts are available.

CUTTING TOOLS: Slicer, julienne and shredder plates feature stainless steel plates with cutlery-grade stainless steel knives. Grater plates feature stainless steel cutting plates with thermoplastic support hubs. Dicing grids have molded frames to

support stainless steel knives. Plate combinations for dicing operations are shown in the table below:

FP150 & FP250 Food Processors								
	DICEGRD-7/32	DICEGRD-5/16	DICEGRD-3/8	DICEGRD-1/2	DICEGRD-1/2L	DICEGRD-5/8	DICEGRD-5/8L	DICEGRD-3/4
15SLICE-1/32-SS								
15SLICE-1/16-SS								
15SLICE-1/8-SS	✓	✓	✓	✓		✓		✓
15SLICE-5/32-SS	✓	✓	✓	✓		✓		✓
15SLICE-7/32-SS	✓	✓	✓	✓		✓		✓
15SLICE-5/16-SS		✓	✓	✓		✓		✓
15SLICE-3/8-SS			✓	✓		✓		✓
15SFSLC-5/16		✓	✓	✓		✓		✓
15SFSLC-3/8			✓	✓		✓		✓
15SFSLC-1/2					✓		✓	
15SFSLC-5/8							✓	

WEIGHT: Net - 45 lbs. Approximate Shipping - 51 lbs.

PRODUCT LOADING



Bulk Feeding

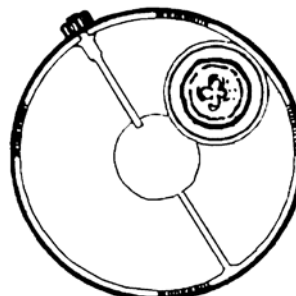

Tube Feeding for Long Products

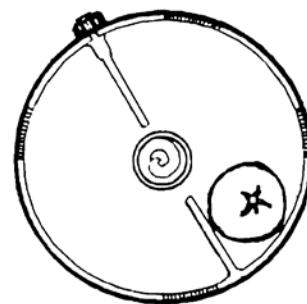

Directional for Definitive Cuts

FP250 FOOD PROCESSOR



701 S Ridge Avenue, Troy, OH 45374
1-888-4HOBART • www.hobartcorp.com

DETAILS AND DIMENSIONS

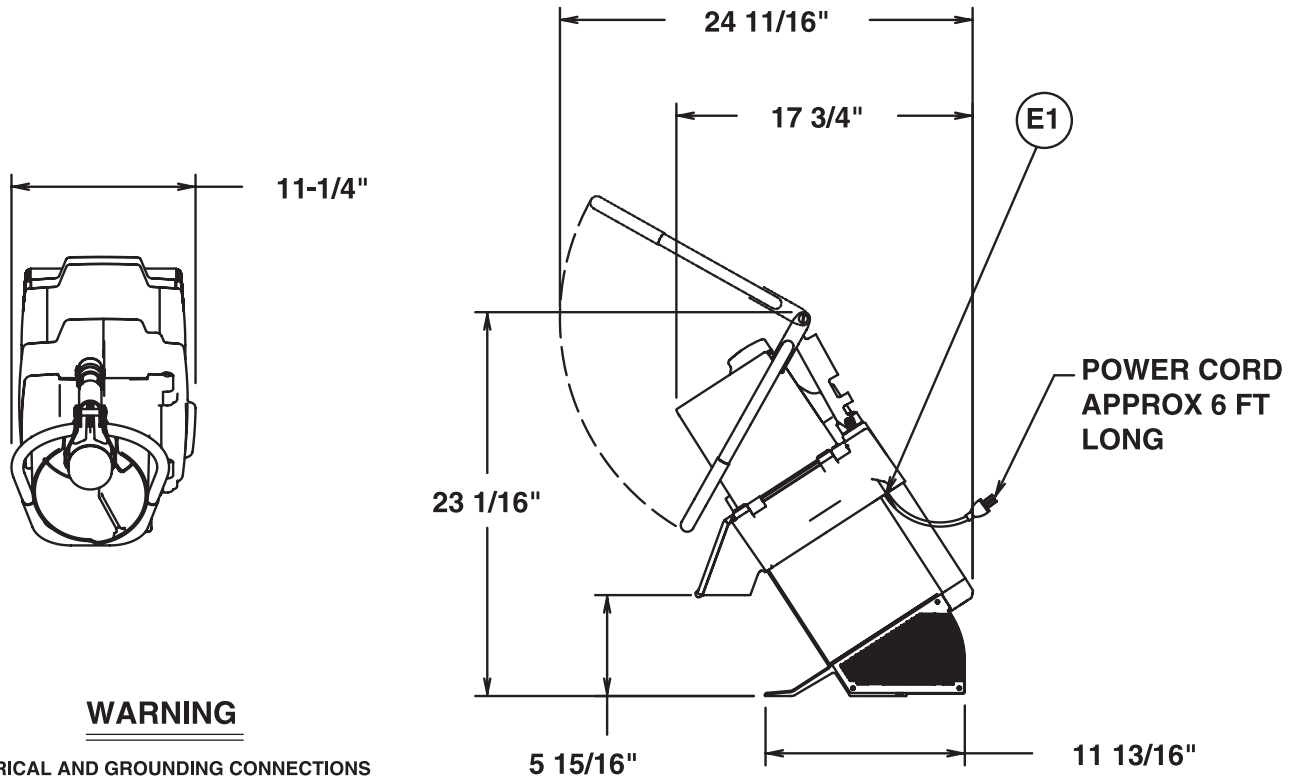

WARNING

ELECTRICAL AND GROUNDING CONNECTIONS MUST COMPLY WITH THE APPLICABLE PORTIONS OF THE NATIONAL ELECTRICAL CODE AND/OR OTHER LOCAL ELECTRICAL CODES.

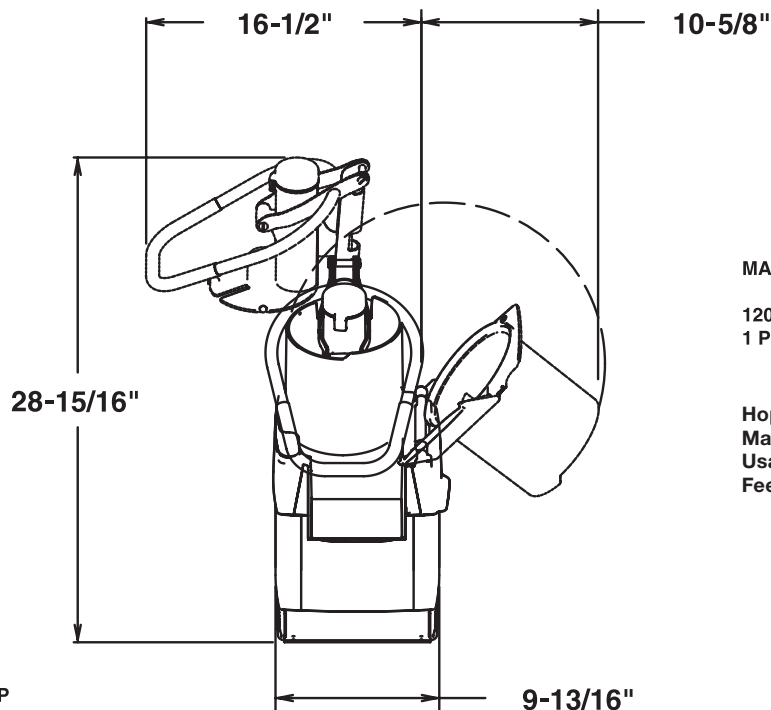

MACHINE ELECTRICAL SPECS

120 V, 60 HZ
1 PH, 8.0 AMPS

Hopper Diameter 6³/₈"
Max. Slice Size 3"
Usable Depth 7"
Feed Tube Dia. 2⁵/₁₆"

LEGEND
E1-ELECTRICAL CONNECTION,
APPROX 12" ABOVE COUNTER TOP

As continued product improvement is a policy of Hobart, specifications are subject to change without notice.