

**HOBART**701 S Ridge Avenue, Troy, OH 45374  
1-888-4HOBART • www.hobartcorp.com**HCM450  
CUTTER MIXER****HOBART****STANDARD FEATURES**

- 5 H.P. Motor
- 45-Quart Capacity Stainless Steel Bowl with Pouring Lip
- Durable Steel Base with Epoxy Enamel Finish
- Electromechanical Safety Interlocks
- Start/Stop Push Button Switches
- 5 Minute Timer with “Hold” and “Jog” Settings
- Counterbalanced Clear Lexan® Polycarbonate Bowl Cover with Stainless Steel Support Bar
- Bowl Tilt Lever
- Stainless Steel Mixing Baffle with Pour-Through Center Shaft
- 2 Blade Cut/Mix Knife
- Knead/Mix Attachment
- Polypropylene Strainer Basket
- 6' Power Cable, Plug and Receptacle

**ACCESSORIES**

- Casters

**MODEL**

- HCM450 — 45-Quart Cutter Mixer with Stainless Steel Bowl, Stainless Steel Mixing Baffle, Cut/Mix Knife, Knead/Mix Attachment and 6' Power Cable with Plug and Receptacle
- HCM450C — Standard 45-Quart Cutter Mixer with Maximum Security Correctional Package (200/60/3 and 460/60/3 only)

Specifications, Details and Dimensions on Inside and Back.

**HCM450 CUTTER MIXER**

# HCM450 CUTTER MIXER



701 S Ridge Avenue, Troy, OH 45374  
1-888-4HOBART • www.hobartcorp.com

## SOLUTIONS / BENEFITS

### 5 H.P. Motor

Durability, Reliability, Consistency

- Heavy-duty to meet the most demanding operations
- Single-speed, 1140 RPM allows for consistent processing of various products

### Electromechanical Safety Interlocks

Safety, Protection

- Prevents operation unless bowl cover is closed and latched
- Prevents operation if bowl is tilted beyond 20 degrees from vertical position

### Start/Stop Push Button Switches

Durability, Reliability

- Switches are completely sealed and washable
- All electric controls are housed in a reinforced polyester, high impact resistance enclosure to insure long life

### 5 Minute Timer with “Hold” and “Jog” Settings

Consistency, Flexibility

- Supports consistent results and thorough processing
- “Hold” and “Jog” settings allow the operator the flexibility needed for non-timed recipes

### Counterbalanced Clear Lexan® Polycarbonate Bowl Cover with Stainless Steel Support Bar

Reliability, Ease of Use

- Clear Lexan® bowl cover effectively seals in liquid product without a rubber gasket
- Counterbalanced for ease in handling
- Stainless steel support bar for long life and durability

### Bowl Tilt Lever

Ease of Use

- Allows bowl to tilt to a 90 degree angle for easy pouring and removal of product
- Makes clean-up easy

### Stainless Steel Mixing Baffle with Pour-Through Center Shaft

Consistency, Productivity, Ease of Use

- Manually operated to move products continually into the shaft blades for better product consistency
- Built-in bowl cover scraper allows for easy viewing of product
- Pour-through center shaft permits addition of liquid products with the cover closed

### Polypropylene Strainer Basket

Economical, Productivity

- Allows re-use of water when cutting head lettuce or other tender vegetables



701 S Ridge Avenue, Troy, OH 45374  
1-888-4HOBART • www.hobartcorp.com

# HCM450 CUTTER MIXER

## SPECIFICATIONS

**MOTOR:** Dual voltage configuration with thermal overload protection, single speed, 1140 RPM, totally enclosed, externally fan cooled, ball bearings, grease packed and sealed. Motor shaft is stainless steel.

**ELECTRICAL:** 200/60/3, 230/60/3 and 460/60/3 – U L Listed.

**CONTROLS:** Magnetically operated start and stop selectors are completely sealed and washable. All electrical controls are housed in a high impact resistance, reinforced polyester enclosure.

**TIMER:** 5 minute, automatically shuts off machine after time set has elapsed. Non-timed operation obtained by setting timer on run or jog.

**POWER CABLE, PLUG AND RECEPTACLE:** 6 foot, flexible type “SO” cable with grounding polarized plug. A grounding polarized power receptacle is furnished. See chart at the bottom of the page for proper size and voltage.

**BRANCH POWER CIRCUIT REQUIREMENTS:** 200 or 230/60/3 machine should be connected to a 30 amp service; 460/60/3 requires 20 amp service.

**BOWL:** Stainless steel, 45-quart capacity with built-in pouring lip to guide liquids into a container. Bowl will tilt 90 degrees to a pour height of 15<sup>3</sup>/<sub>8</sub>" from the floor. All stainless steel.

**BOWL COVER:** <sup>3</sup>/<sub>16</sub>" clear Lexan® Polycarbonate that seals effectively without a gasket. Counterbalanced for ease of handling. Cover support bar is stainless steel.

**BOWL TILT MECHANISM:** A lever is provided to control the bowl for “hold” position when running or “tilt” to empty. When set to “hold” there is a firm grip to prevent tipping of the bowl during normal operation. “Tilt” setting releases the hold but provides a constant preset drag, which allows pivoting but will hold the bowl in any position. The bowl and motor are counterbalanced for easy handling.

**MIXING BAFFLE:** All stainless steel. Manually operated to move products continually into the shaft blades. Exclusive pour-through center shaft permits addition of liquid ingredients with the cover closed, the baffle in position and the machine operating. Exclusive built-in scraper, located on the mixing baffle, helps keep the cover clean during operation, and enables easy cleaning of the cover before opening. Baffle removable for cleaning.

**SAFETY:** Electromechanical interlocks prevent operation unless bowl cover is closed and latched. Interlock also prevents operation if bowl is tilted beyond 20 degrees from vertical position. A centrifugal brake stops motor when the stop switch is pushed or an interlock shuts off electrical power.

**BASE:** Rectangular steel tubing, formed and welded. Finished in gray epoxy-based enamel.

**STANDARD EQUIPMENT:** Consists of Cutter Mixer unit with manually operated mixing baffle; polypropylene strainer basket, cut/mix attachment, knead/mix attachment; 6 foot power cable with plug and power receptacle.

**ACCESSORIES:** Casters, Extra Basket Kit

**NET WEIGHT:** 282 lbs.

**SHIPPING WEIGHT:** 362 lbs.

VOLTAGE	PLUG & RECEPTACLE	OPTIONAL PENDANT
200/60/3	Hubbell 2811/L21-30P Hubbell 2810/L21-30R	Hubbell 2813/L21-30R
230/60/3	Woodhead 28W75 L15-30P Woodhead 69W75 L15-30R	Woodhead 29W75 L15-30R
460/60/3	Woodhead 26W76L16-20P Woodhead 67W76L16-20R	Woodhead 27W76 L16-20R

# HCM450 CUTTER MIXER



701 S Ridge Avenue, Troy, OH 45374  
1-888-4HOBART • www.hobartcorp.com

## DETAILS AND DIMENSIONS

### WARNING

ELECTRICAL AND GROUNDING CONNECTIONS MUST COMPLY WITH THE APPLICABLE PORTIONS OF THE NATIONAL ELECTRICAL CODE AND/OR OTHER LOCAL ELECTRICAL CODES.

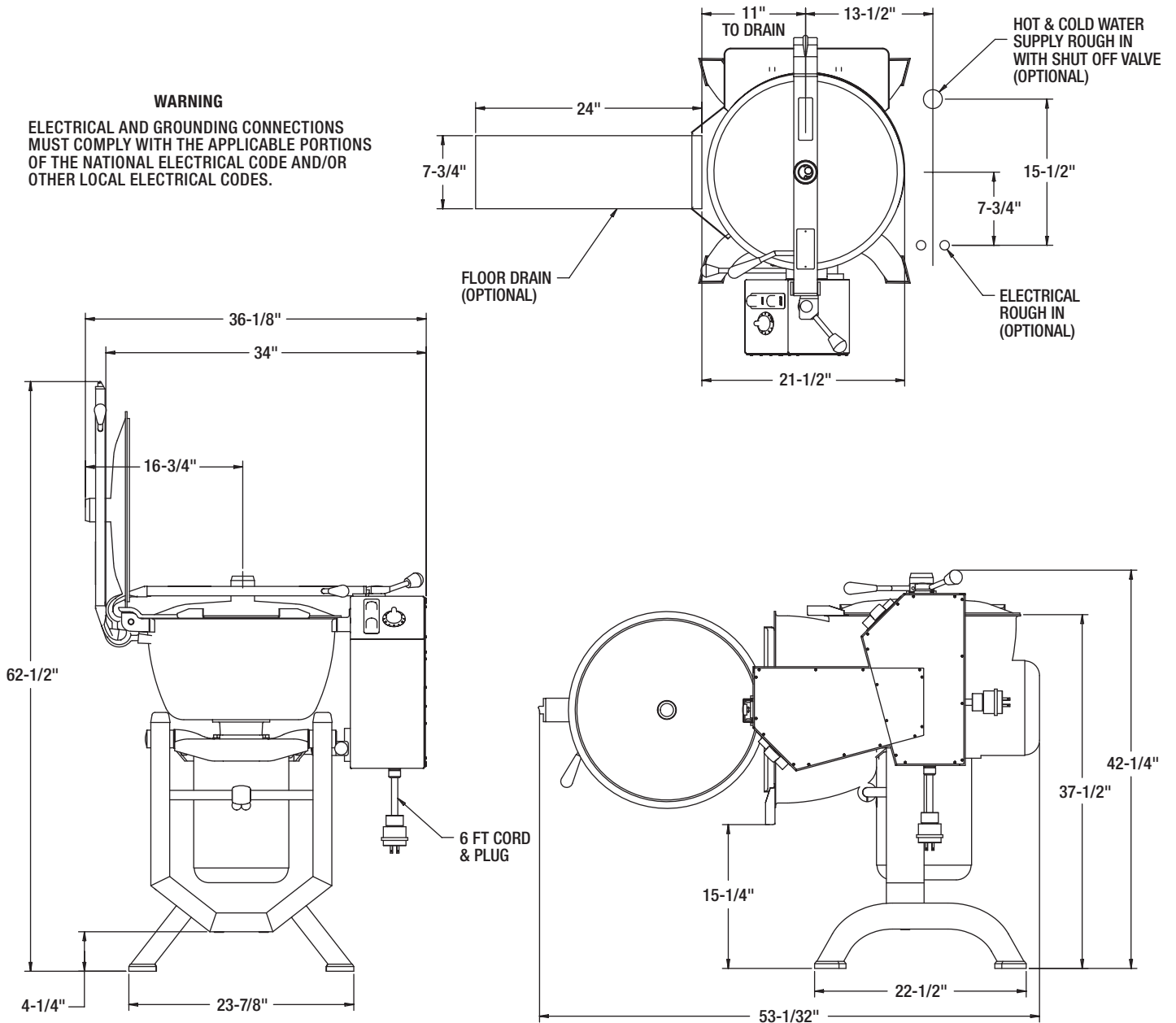

As continued product improvement is a policy of Hobart, specifications are subject to change without notice.