



# Electrolux

## Food Processor Cutter Mixer 7 LT - 2 Speed

ITEM # \_\_\_\_\_

MODEL # \_\_\_\_\_

NAME # \_\_\_\_\_

SIS # \_\_\_\_\_

AIA # \_\_\_\_\_



Food Processor  
Cutter Mixer 7 LT - 2 Speed

603318 (K702V) Cutter Mixer 7 LT - Two  
Speed - 380-440V/3/50-60

### Short Form Specification

Item No. \_\_\_\_\_

2 in 1 machine: table-mounted cutter and emulsifier thanks to the ergonomic and easily dismantlable scraper, in heavy duty composite material, for liquidising, mixing and mincing in a matter of seconds. Stainless steel 7 litre bowl with high chimney to increase the real capacity of the bowl (use up to 75% of nominal capacity). Unique bowl design for mixing both large or small quantities. Transparent lid to check consistency of food and to eventually add ingredients without having to open the lid. Hinged cover, when lifted, remains open to permit a fast and easy check of preparation. Micro toothed blades in 420 AISI stainless steel. All parts are easily dismantled and dishwasher safe. Multiple safety devices ensure the machine will only operate when the cover is properly closed and all parts are correctly positioned. Flat and waterproof control panel with on/off button, pulse function and 2 speeds (1500/3000 rpm).

### Main Features

- Table-mounted robust cutter and emulsifier allows fast liquidizing, mixing, chopping, mincing, and pastry-making.
- Emulsifier function (scraper) included as standard.
- Base fixed cover for a better handling.
- Lid with central opening to add ingredients in mid-cycle.
- All parts in contact with food are removable without the use of tools, completely dismantlable and dishwasher safe.
- Flat and waterproof control panel with on/off button and pulse function.
- Microswitch and safety devices on handle, lid and bowl.
- Pulse function to coarse chopping.
- Productivity suitable for 50-150 meals per service

### Construction

- Stainless steel 7 liter bowl has a high chimney to ensure high productivity also when processing liquids (75% of the nominal capacity).
- Microtoothed blades in 420 AISI stainless steel and ergonomic scraper in high resistant composite material to ensure consistent mixing.
- 2 speeds: 1500 and 3000 rpm.
- Transparent lid incorporates a magnetic contact safety system.

### Included Accessories

- 1 of Microtoothed blade rotor for PNC 7 lt cutter mixer 653584
- 1 of Lid and bowl scraper for 7 lt PNC cutter mixer 653592
- 1 of Stainless steel bowl for 7 lt PNC cutter mixer 653593

### Optional Accessories

- Microtooth blade rotor (emulsifier) for 7 lt cutter mixer PNC 650041
- Smooth blade rotor for 7 lt cutter PNC mixer 653583
- Microtoothed blade rotor for 7 lt PNC cutter mixer 653584
- Lid and bowl scraper for 7 lt PNC cutter mixer 653592
- Stainless steel bowl for 7 lt cutter PNC mixer 653593
- Smooth blade rotor (emulsifier) for 7 lt cutter mixer PNC 653712

APPROVAL: \_\_\_\_\_



Electrolux

Food Processor  
Cutter Mixer 7 LT - 2 Speed

Front

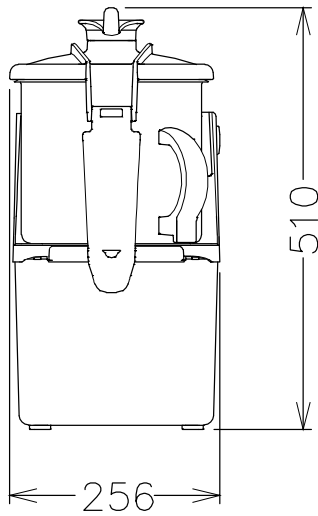

Top

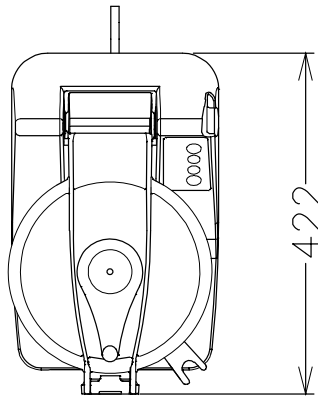

EI = Electrical connection

Side

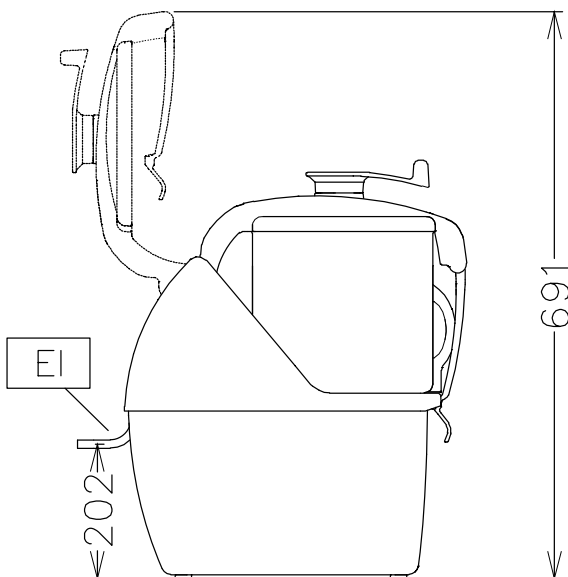
**Electric**
**Supply voltage:**

603318 (K702V) 380-440 V/3 ph/50/60 Hz

**Electrical power max.:** 1.2 kW

**Total Watts:** 1.2 kW

**Capacity:**
**Performance (up to):** 3.5 - kg/Cycle

**Capacity:** 7 liter

**Key Information:**
**External dimensions, Height:** 510 mm

**External dimensions, Width:** 256 mm

**External dimensions, Depth:** 422 mm

**Shipping weight:** 23 kg

**Waterproof index:** IP34