



Electrolux

Food Processor Cutter Mixer 3.5 LT - Single Speed

ITEM # _____

MODEL # _____

NAME # _____

SIS # _____

AIA # _____



Food Processor
Cutter Mixer 3.5 LT - Single Speed

603840 (K35Y) Cutter Mixer 3.5 LT - Single
Speed - 220-240V/1/50

Short Form Specification

Item No. _____

Robust cutter for liquidising, mixing and mincing in a matter of seconds. AISI 302 stainless steel 3,5 litre bowl. Lid incorporates opening to add ingredients in mid-cycle. Transparent cover incorporates a magnetic contact safety system. Finely toothed blade rotor. Angled blades and conical base of the bowl ensure consistent mixing. Parts in contact with food are removable and dw safe. 1 speed rotor: 1500 rpm.

Main Features

- Robust cutter allows fast liquidizing, mixing, mincing and chopping.
- Angled blades and conical base of the bowl ensure consistent mixing.
- Lid with central opening to add ingredients in mid-cycle.
- Delivered with:
-3,5 lt stainless steel bowl with finely toothed blades rotor
- Parts in contact with food are removable and dishwasher safe.
- Pulse function to coarse chopping.
- Productivity suitable for 10-50 meals per service.

Construction

- 302 AISI stainless steel bowl is positioned on the central shaft. Bowl supplied with a leak resistant spout.
- Speed motor: 1.500 rpm.
- Transparent lid incorporates a magnetic contact safety system.

Included Accessories

- 1 of Finely toothed blade rotor for 3,5 lt cutter mixer PNC 653028
- 1 of Stainless steel bowl for 3,5 lt cutter mixer PNC 653096

Optional Accessories

- Finely toothed blade rotor for 3,5 lt cutter mixer PNC 653028
- Smooth blade rotor for 3,5 lt cutter mixer PNC 653029
- Stainless steel bowl for 3,5 lt cutter mixer PNC 653096

APPROVAL: _____



Electrolux

Food Processor
Cutter Mixer 3.5 LT - Single Speed

Front

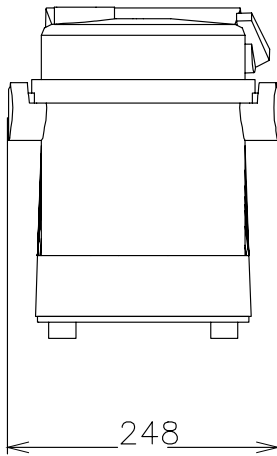

Top

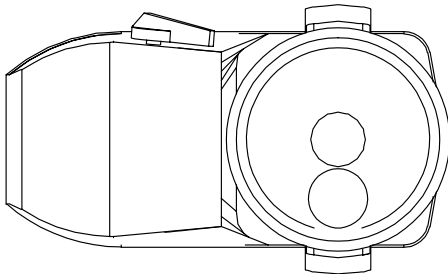

EI = Electrical connection

Side

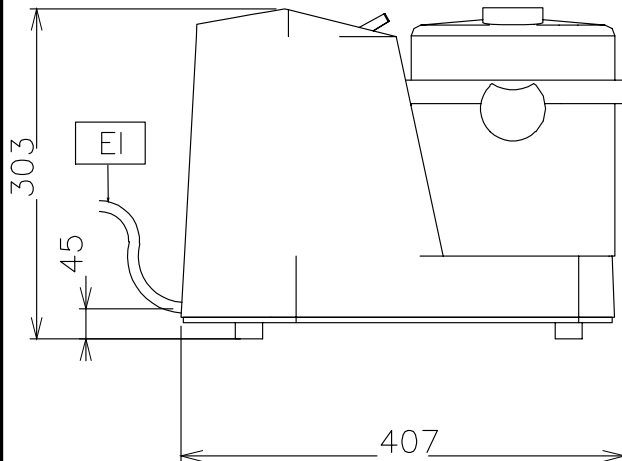
Electric

Supply voltage:	
603840 (K35Y)	230-240 V/1N ph/50 Hz
Electrical power max.:	0.5 kW
Total Watts:	0.5 kW

Capacity:

Performance (up to):	1.8 - kg/Cycle
Capacity:	3.5 liter

Key Information:

External dimensions, Height:	303 mm
External dimensions, Width:	247 mm
External dimensions, Depth:	407 mm
Shipping weight:	17 kg